

Operating instructions

HR83 and HR83-P Moisture Analyzers

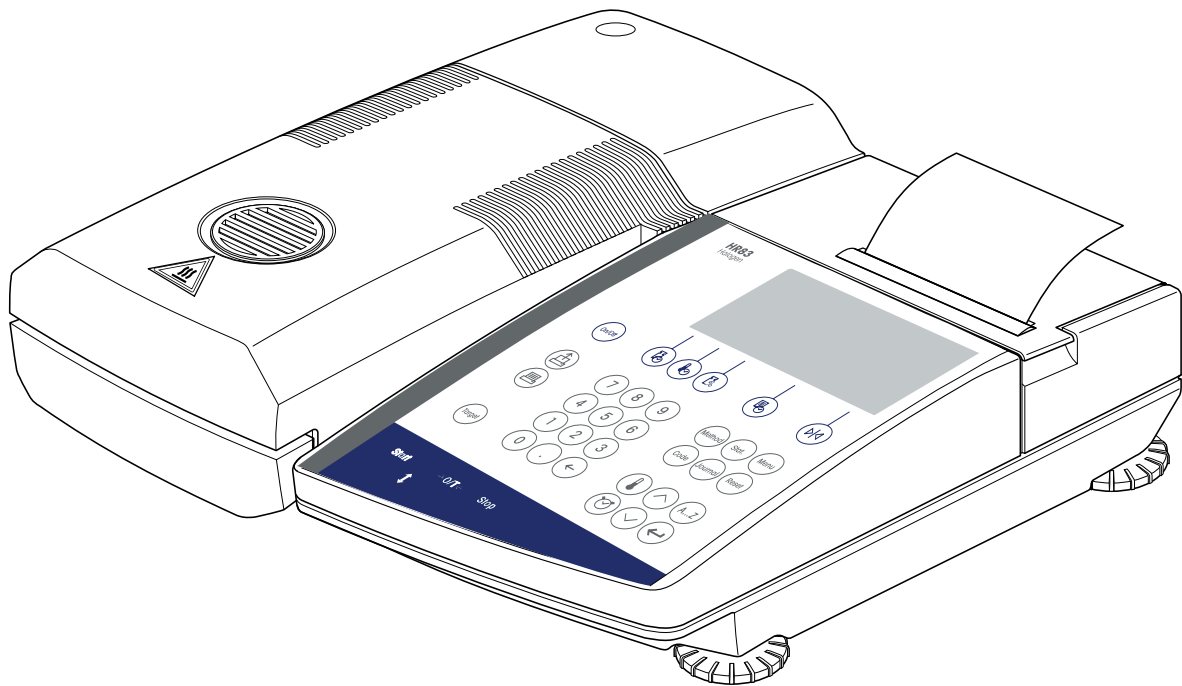

Overview of your HR83 Halogen Moisture Analyzer

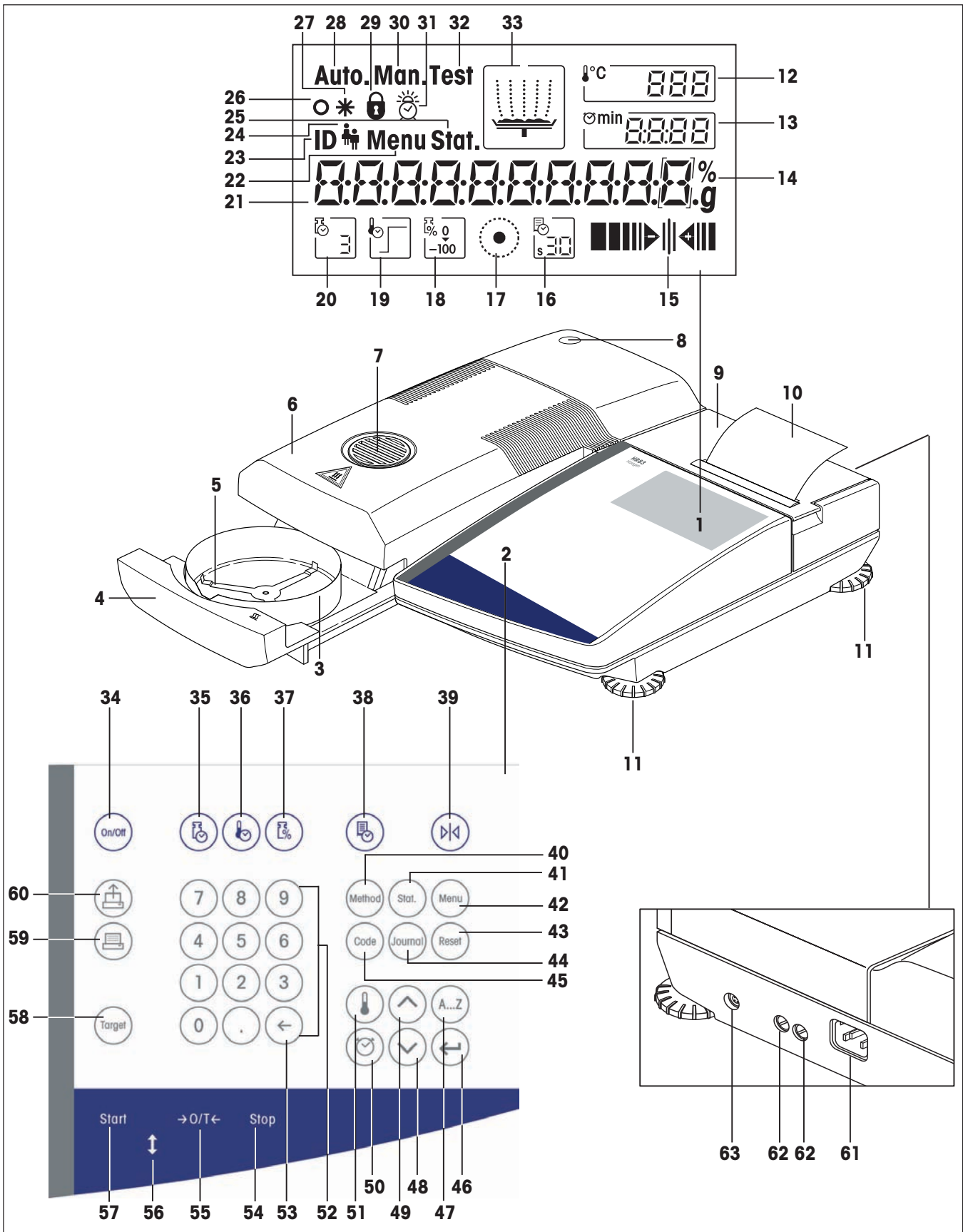

Display, controls and connections of your HR83

No.	Designation	Info see Section	No.	Designation	Info see Section
1	Display	all	31	Symbol for audio signal device (beeper)	6.12
2	Keypad	all	32	Symbol for test measurement	4.11/4.12
3	Draft shield	2.3	33	Status display (User guide)	2.6
4	Automatic sample chamber	2.6	34	Key «On/Off»	2.6
5	Sample pan holder	2.3	35	Function key «Switch-off criterion»	4.4
6	Heating module	7.6	36	Function key «Drying program»	4.2
7	Inspection window and vent	6.4	37	Function key «Display mode»	4.5
8	Level indicator (level)	2.3	38	Function key «Print interval»	4.6
9	Printer cover	7.2	39	Key «Target weight» (weighing-in aid)	4.7
10	Built-in printer (option)	7.5	40	Key «Method» (method selection)	5.2
11	Leveling screw	2.3	41	Key «Stat.» (statistics)	5.12
12	Display of drying temperature	4.3	42	Key «Menu»	6
13	Display of drying time / Method number (Selection) / Comment line (C1 – C4)	4.4	43	Key «Reset»	2.6
14	Display of unit (percent or grams)	4.5	44	Key «Journal»	5.11
15	Weighing-in aid	4.7	45	Key «Code» (record comment)	4.8
16	Function display "Print interval"	4.6	46	Key «Accept entry»	all
17	Function display "AutoMet"	4.12	47	Key «A...Z» (alphanumeric entry)	4.8/5.3
18	Function display "Display mode"	4.5	48	Key «Scroll down»	2.5
19	Function display "Drying program"	4.2	49	Key «Scroll up»	2.5
20	Function display "Switch-off criterion"	4.4	50	Key «Drying time»	4.4
21	Dialog display (measured values, menu dialog, text entry, etc.)	all	51	Key «Drying temperature»	4.3
22	Menu symbol	6	52	Numeric keypad	4.1
23	Method symbol	5	53	Key «Delete»	4.1
24	Symbol for record comment	4.9	54	Key «Stop» (stop drying)	4.9/4.10
25	Statistics symbol	5.12	55	Key «Tare» (zero)	2.6
26	Stability detector	8.2/8.3	56	Key «Open/close auto sample chamber»	2.6
27	Symbol for calculated result	2.6/5.11	57	Key «Start» (start of drying)	2.6
28	Symbol for automatic operating mode of the automatic sample chamber	6.11	58	Key «Target»	4.12
29	Symbol for Key protection (with and without password)	6.13	59	Key «Print»	4.10/6.1
30	Symbol for manual operating mode of the automatic sample chamber	6.11	60	Key «Paper feed»	2.4/7.2
			61	Power supply receptacle	2.3
			62	Power line fuses	7.3
			63	LocalCAN universal interface port	9.2

Contents

1	Getting to know your Moisture Analyzer	6
1.1	Introduction	6
1.2	What is the Halogen Moisture Analyzer used for?	6
1.3	Safety has priority	7
1.4	Disposal	9
1.5	Important information for these instructions	10
2	Your first measurement in next to no time	11
2.1	Unpacking and checking the standard equipment	11
2.2	Selecting the location	12
2.3	Setting up, leveling and connecting to power supply	12
2.4	Preparing the printer	15
2.5	Setting the date and time	16
2.6	Your first measurement	18
3	How to obtain the best results	22
3.1	Measurement principle of the Halogen Moisture Analyzer	22
3.2	Notes on adjustment of the balance and the heating module	23
3.3	Optimum sample preparation	23
3.4	Further information on moisture determination	24
4	Practical application of your Moisture Analyzer	25
4.1	Operating principles	25
4.2	Selecting the drying program	26
4.3	Setting the drying temperature	27
4.4	Selecting the switch-off criterion	30
4.5	Selecting the display mode	33
4.6	Defining the print interval	35
4.7	Working with the weighing-in aid	36
4.8	Comment lines	38
4.9	Information on the measurement record	40
4.10	Performing a measurement	42
4.11	Test measurement	46
4.12	AutoMet test measurement	47
5	Methods facilitate your work	51
5.1	What is a method?	51
5.2	Recalling a method	52
5.3	Naming, compiling or changing methods	52
5.4	Method menu	55
5.4.1	Freely selectable switch-off criterion	56
5.4.2	Free factor (-MC)	57
5.4.3	Free factor (g)	58
5.4.4	Compiling methods	58
5.4.5	High resolution	60
5.4.5.1	Standby temperature	60
5.4.5.2	Recording the settings	62
5.4.6	Drying temperature to 200 °C without time limitation	63
5.5	Printing out methods	63
5.6	Measured value journal	65
5.7	Measured value statistics	66

6	The menu (basic settings of the instrument)	69
6.1	Password protection	70
6.2	Adjusting the balance	73
6.3	Testing the balance	74
6.4	Adjusting the heating module	75
6.5	Testing the heating module	77
6.6	Resetting to the factory settings	80
6.7	Clearing the method memory	81
6.8	Setting the time	81
6.9	Entering the date	82
6.10	Setting the vibration adapter	82
6.11	Selecting operating mode of the automatic sample chamber	83
6.12	Audio signal	83
6.13	Protecting your settings against change	84
6.14	Superimposing or removing the function symbols	84
6.15	Switching the printer on or off	85
6.16	Entering company name for printed records	85
6.17	Selecting the type of record	86
6.18	Defining the free print interval	86
6.19	Switching the statistics and journal functions on and off	87
6.20	Selective clearing of comment lines	87
6.21	Defining the test weight	88
6.22	Tolerance for balance test	88
6.23	Selecting the dialog language	89
6.24	Menu overview HR83	90
7	Servicing and replacing individual parts	91
7.1	Cleaning	91
7.2	Changing the printer paper and ribbon	92
7.3	Replacing the power line fuses	93
7.4	Printer test	94
7.5	Installing the built-in printer	94
7.6	Dismantling and replacing the heating module	94
8	If problems arise on occasion	96
8.1	Notes on the error messages	96
8.2	Meaning of the error messages	97
8.3	What if...?	99
9	Further useful information	103
9.1	Notes on interpretation of the measurement results and the ideal sample weight	103
9.2	LocalCAN universal interface	103
9.3	Barcode Reader	104
9.4	Application brochure	104
9.5	Switch-off criterion "Weight loss per unit of time"	104
9.6	Comments on certified version	105
9.7	Technical data	106
9.8	MT-SICS Interface commands and functions	109
9.9	Optional equipment, expendable material and spare parts	111
10	Index	112

1 Getting to know your Moisture Analyzer

Please read through this Section carefully, it contains important information for safe and economical operation of your Moisture Analyzer.

1.1 Introduction

Thank you for deciding to purchase a Halogen Moisture Analyzer from METTLER TOLEDO – you have made a wise choice. Your Moisture Analyzer is fast and reliable. It offers a high level of operating convenience and useful functions to facilitate determination of the moisture content of your samples

Behind your instrument stands METTLER TOLEDO, a leading manufacturer of not only balances and scales for the lab and production, but also analytical measuring instruments. A customer service network covering the entire globe with well trained personnel is at your service at all times, whether you are choosing accessories or require guidance for a specific application to ensure optimum utilization of your instrument.

To ensure you make full use of the possibilities offered by your Moisture Analyzer, we advise you to read through these operating instructions very carefully.

1.2 What is the Halogen Moisture Analyzer used for?

Your Halogen Moisture Analyzer is used for determining the moisture content of almost any substance. The instrument works on the thermogravimetric principle: At the start of the measurement the Moisture Analyzer determines the weight of the sample, the sample is then quickly heated by the integral halogen heating module and the moisture vaporizes. During the drying process the instrument continually measures the weight of the sample and displays the reduction in moisture. Once drying has been completed, the moisture or solids content of your sample is displayed as the final result.

Of decisive importance in practice is the rate of heating. In comparison with conventional infrared heating or the drying oven method, for example, the halogen heating module of your instrument needs a shorter time to reach its maximum heating power. It also allows use of high temperatures, an additional factor in shortening the drying time. Uniform heating of the sample material ensures good repeatability of the drying results and makes it possible to use a smaller amount of sample.

All parameters of a measurement (drying temperature, drying time, etc.) can be preselected. But your Moisture Analyzer offers many other possibilities. To avoid exceeding the scope of this introduction, only a few of these are listed here:

- In the built-in methods database 40 different methods can be individually optimized to suit your samples. They are simple to activate at the touch of a key.
- You can set a reference value for which the optimum switch-off criterion is determined automatically in a test measurement (AutoMet).
- You can choose between various types of result display at any time.
- Your settings and measurement results can be recorded, stored and protected (3-level password protection).
- Up to 4 comment lines can be entered per measurement (with optional use of a Barcode Reader).
- Thanks to the built-in rechargeable battery your valuable data remain stored even on power failure.

This wealth of functions notwithstanding, your Moisture Analyzer is very simple to operate. The status display (User guide) guides you step by step through the measurement cycle. You always know which particular stage in a measurement is currently being executed by the instrument and the next operating step. To exclude faulty handling in routine work, the keypad can be locked (3-level password protection) to prevent access to all but the elementary functions. The motorized, automatic sample chamber offers the operating convenience you are familiar with from compact disk (CD) players. Moreover, the motorized sample chamber opens up new possibilities for automatic operation of the instrument (loading by means of robots) when used with the LocalCAN universal interface installed as standard.

Besides operating convenience, however, the quality of the measurement results is still what counts above all. The built-in weighing cell meets the high standard which has made METTLER TOLEDO the worldwide market leader in the field of high-resolution precision balances.

A brief word regarding standards, directives and procedures for quality assurance. The Moisture Analyzer conforms with all common standards and directives. It supports stipulations, work techniques and result records as demanded by all international quality assurance systems, e.g. **GLP (Good Laboratory Practice)**, **GMP (Good Manufacturing Practice)**. The instrument has a EC declaration of conformity and METTLER TOLEDO as the manufacturer has been awarded ISO 9001 and ISO 14001 certification. This provides you with the assurance that your capital investment is protected in the long term by a high product quality and a comprehensive service package (repairs, maintenance, servicing, calibration service).

You will find further information in the following Sections of these operating instructions. Please read through this information carefully to ensure you can use your instrument in an optimum and safe manner.

1.3 Safety has priority



Your Moisture Analyzer employs state of the art technology and meets the latest demands regarding instrument safety. This notwithstanding, improper operation can endanger personnel and cause damage to tangibles. For safe and dependable operation, please comply with the following instructions:

- The Moisture Analyzer is used for determining the moisture in samples. Please use the instrument exclusively for this purpose. Any other type of use can endanger personnel and damage the instrument or other tangibles.
- The Moisture Analyzer must not be operated in a hazardous environment and only under the ambient conditions specified in these instructions.
- The Moisture Analyzer may be operated only by trained personnel who are familiar with the properties of the samples used and with the handling of the instrument.
- Your Moisture Analyzer is supplied with a 3-pin power cable with an equipment grounding conductor. Only extension cables which meet the relevant standards and also have an equipment grounding conductor may be used. Intentional disconnection of the equipment grounding conductor is prohibited.



**The Halogen Moisture Analyzer works with heat!**

- Ensure sufficient free space around the instrument to avoid heat accumulation and overheating (approx. 1 m free space above the instrument).
- The vent over the sample must never be covered, plugged, taped over or tampered with in any other way.
- Do not place any combustible materials on, under or next to the instrument when it is connected to the power supply, since the area around the heating module becomes hot.
- Exercise caution when removing the sample. The sample itself, the automatic sample chamber and any sample vessels used may still be very hot.
- During operation, you should never open the heating module as the ring-shaped heating module or its protective glass can reach 400 °C! If you have to open the heating module on occasion, disconnect the instrument from the power supply and wait until the heating module has cooled down completely.
- No modifications must be made within the heating module. It is particularly dangerous to bend any components or remove them, or to make any other changes.

Certain samples require special care!

With certain types of samples, there is a possibility of danger to personnel or damage to tangibles through:

**Fire or explosion:**

- Flammable or explosive substances
- Substances containing solvents
- Substances which evolve flammable or explosive gases or vapors when heated.

With such samples, work at a drying temperature that is low enough to prevent the formation of flames or an explosion and wear protective goggles. Should there be any uncertainty regarding the flammability of a sample, always work with a small amounts of sample (max. 1 gram). In such cases, **never leave** the instrument **unattended!** In cases of doubt, perform a careful risk analysis.

Poisoning, burning:

- Substances which contain toxic or caustic components. Such substances may be dried only in a fume cupboard.

Corrosion:

- Substances which evolve corrosive vapors when heated (e.g. acids). In the case of such substances, we advise you to work with small amounts of sample as the vapor can condense on cooler housing parts and cause corrosion (if necessary, the heating module can be changed very easily by the user, see Section 7.6).

Please note that the user always takes responsibility and assumes liability for damage caused by use of the types of samples mentioned above!

- Never make any modifications or constructional alterations to the instrument and use only original spare parts and optional equipment from METTLER TOLEDO.
- Your Moisture Analyzer is a rugged precision instrument – but you should still treat it carefully; it will then thank you with many years of trouble-free operation.
- **Please comply with all notes and instructions in these operating instructions. Keep the instructions in a safe place where they are immediately to hand if any points are unclear. If you lose these instructions, please contact your METTLER TOLEDO dealer for an immediate replacement.**



Moisture determination applications must be optimized and validated by the user according to local regulations. Application-specific data provided by METTLER TOLEDO is intended for guidance only.

1.4 Disposal



In conformance with the European Directive 2002/96/EC on Waste Electrical and Electronic Equipment (WEEE) this device may not be disposed of in domestic waste.

This also applies to countries outside the EU, per their specific requirements.

Please dispose of this product in accordance with local regulations at the collecting point specified for electrical and electronic equipment.

If you have any questions, please contact the responsible authority or the distributor from which you purchased this device.

Should this device be passed on to other parties (for private or professional use), the content of this regulation must also be related.

Thank you for your contribution to environmental protection.

1.5 Important information for these instructions

These instructions guide you step by step through the operation of your Moisture Analyzer. The first two Sections help you put the instrument into operation quickly, safely and properly and perform your first measurement within a short space of time. In Sections 3 through 6 you become intimately acquainted with the wide range of functions of your Moisture Analyzer. During this learning phase, you will find the table of contents and the detailed index in Section 10 a valuable orientation aid. Sections 7 through 9 contain additional information on the maintenance of your instrument, troubleshooting and the available options. As soon as you are familiar with your Moisture Analyzer, you will find the illustrations at the beginning of these instructions and the associated references (in the key) useful for quick access.

The following identifications and symbols are used in these instructions:

- Key designations are shown enclosed by twin angle brackets «». Keys with inscribed text are shown with the actual inscription (e.g. «On/Off» or «Start»). For all keys with symbols, designations are used in the text which describe the function of the particular key («Print», «Accept entry» or «Scroll down»).
- This symbol indicates safety and hazard instructions. If these are not complied with, injury to the user, damage to your instrument or other tangibles and malfunctions can result.
- This symbol indicates additional information and directions which facilitate your handling of the instrument and contribute to proper and economical use.

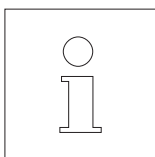

These instructions are also available in foreign languages. Should you require a set of instructions in a different language, please contact your METTLER TOLEDO dealer. You will find the address of your nearest dealer in the attached "Declaration of Conformity 11780294".

2 Your first measurement in next to no time

In the Section you will learn how to put your new Moisture Analyzer into operation and obtain measurement results within a very short space of time.

2.1 Unpacking and checking the standard equipment

Open the package and remove the instrument and the accessories. Check the completeness of the delivery. The following accessories are part of the standard equipment of your new Moisture Analyzer:

- 80 aluminum sample pans
- 1 sample holder
- 1 sample handler
- 1 specimen sample (circular, absorbent glass fiber filter)
- 1 draft shield element
- 1 power cable
- 1 set of operating instructions, 1 set of short-form operating instructions
- 1 Application brochure “Methods of moisture content determination”
- 1 EC declaration of conformity (in separate brochure 11780294)
- Setup instructions

Remove the wrapping from the instrument.

Check the instrument for transport damage. Immediately inform your METTLER TOLEDO dealer if you have any complaints or parts are missing.

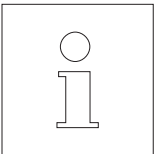

Store all parts of the packaging. This packaging guarantees the best possible protection for the transport of your instrument.

To prevent transport damage, the instrument is provided with a **transport arrestment**, which you have to remove before putting the instrument into operation for the first time. The procedure for removing the transport arrestment is explained in the description “Setup instructions 11780556” enclosed with the package.

2.2 Selecting the location

Your Moisture Analyzer is a precision instrument. An optimum location guarantees accuracy and dependability:

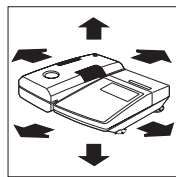
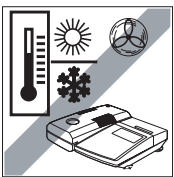
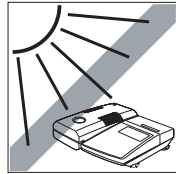
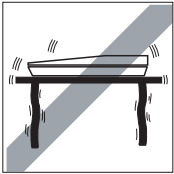

- Firm, horizontal location as free from vibrations as possible
- Avoid direct sunlight
- No excessive temperature fluctuations
- No powerful drafts
- Surroundings as free from dust as possible
- Adequate free space at the front for opening the sample chamber and sufficient clearance around the instrument to allow warm air to dissipate.
- Sufficient distance from heat-sensitive materials in the vicinity of the instrument.

2.3 Setting up, leveling and connecting to power supply

Exact horizontal positioning and stable installation are prerequisites for repeatable results. To compensate small irregularities or inclinations ($\pm 2\%$) at the location, the instrument can be leveled.

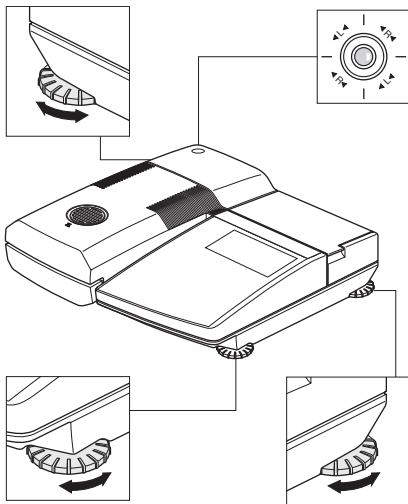

For exact horizontal positioning, the Moisture Analyzer has a level indicator (level) and 3 leveling screws. As soon as the air bubble is precisely in the middle of the cross hairs, the instrument is exactly horizontal. To level it, proceed as follows:

Position your Moisture Analyzer at the selected location.

Screw in the right front leveling screw completely (it is not needed for leveling). The instrument is now standing on the front left, nonadjustable foot, as well as on the two rear leveling screws.

Turn the two **rear** leveling screws until the air bubble is located in the middle of the level indicator. The arrows and the leveling screw designations (R = right rear leveling screw, L = left rear leveling screw) on the cross hairs will facilitate the setting:

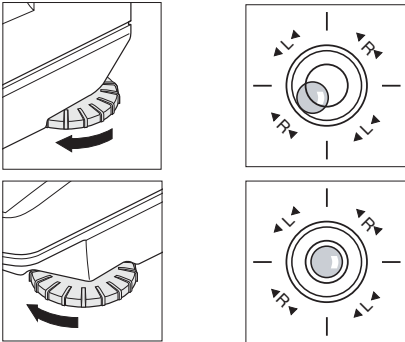

If the air bubble is located at the bottom left, for instance, the inscription indicates the right leveling screw must be turned in a clockwise direction. Unscrew the front right leveling screw until it contacts the support and the instrument is resting firmly on all 4 feet. Ensure that the air bubble remains in the center of the level indicator.

Note: The instrument should be leveled each time its location is changed.

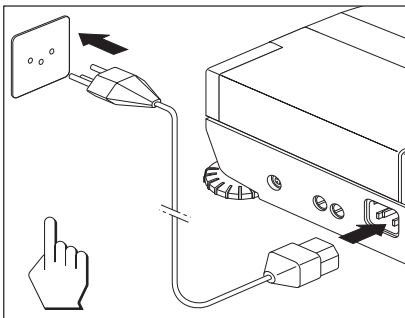

Connect the instrument to the power supply.

Warning

If the power cable supplied is not long enough, use only a **3-pin extension cable with equipment grounding conductor!**

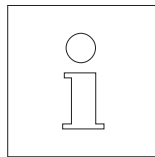

For technical reasons, the halogen heating module is designed specifically for a particular line voltage (110 V AC or 230 V AC). A heating module is installed in the factory that is matched to the particular line voltage of the country of destination. If you are not sure whether the heating module built into your instrument is suitable for your local line voltage, check the voltage data in the interior of the heating module before you connect the Moisture Analyzer to the power supply!



Connection to a line voltage that is too high can lead to blowing of the fuses, whereas a supply voltage that is too low will prolong the drying process.

Ensure that the transport arrestment is removed. Instructions on how to remove the transport arrestment can be found on the leaflet enclosed with the package.



Switch the instrument on with the «On/Off» key.

Note: When putting into operation for the first time, leave the instrument connected to the power supply for at least 5 hours to allow the built-in battery to charge up! If the instrument is later disconnected from the power supply for several months, the battery will become discharged. This leads to data loss. To recharge the battery, leave the instrument connected to the power supply for at least 5 hours.



Press the «Open/close auto sample chamber» key and ...

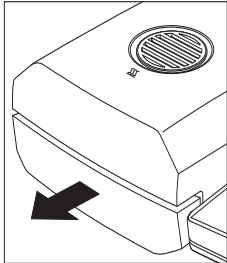

... the motorized, automatic sample chamber opens.

Always ensure **sufficient free space in front of the instrument** since the emerging automatic sample chamber could knock over objects in its path or push them off the bench.

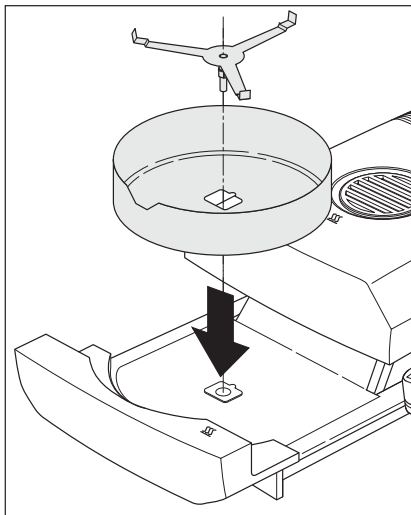

Install the draft shield element (only one position possible) and then the sample pan holder. Turn the sample pan holder until it engages. In the locked position, the rear arm of the sample pan holder points exactly in the direction of motion of the automatic sample chamber.



Press the «Open/close auto sample chamber» key and ...

... the motorized, automatic sample chamber closes.

2.4 Preparing the printer

If your Moisture Analyzer is not equipped with a built-in printer, there is no need to read this Section. You can always order the built-in printer at a later date and install it yourself.

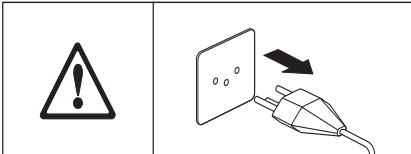

You can prepare the built-in printer for use as follows:

Disconnect the instrument from the power supply.

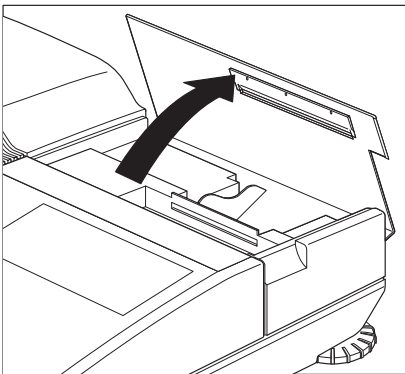

Swing back the cover of the printer.

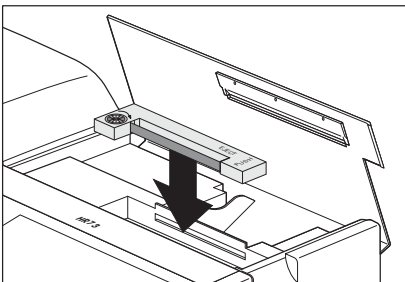

Insert the ribbon cassette in the printer and press it down until you hear it click into place.

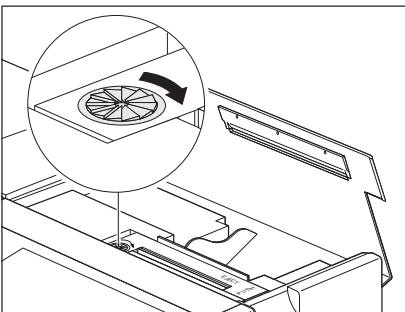

Tension the ribbon by turning the small wheel on the left of the cassette in the direction shown by the arrow.

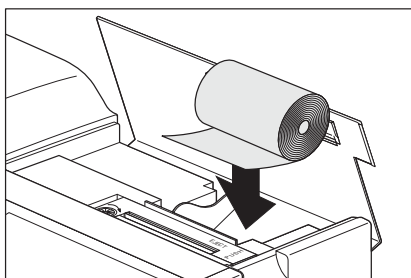

Place the roll of paper in the paper compartment and feed the paper horizontally through the slot at the back of the printing unit.



Connect the instrument to the power supply and switch it on with the «On/Off» key. Press the «Paper feed» key until the leading edge of the paper exits the printing unit at the top.

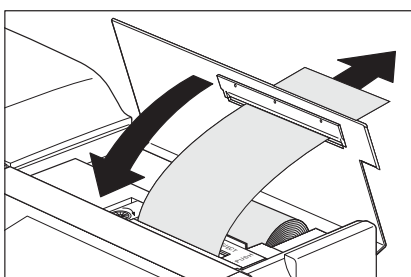

Lead the paper through the slot in the cover of the built-in printer and close the cover.

2.5 Setting the date and time

Your Moisture Analyzer prints out the date and time on every record. When you put your new instrument into operation for the first time, you should enter the current date and the time. These settings are retained even if you disconnect your instrument from the power supply.

In this Section you will enter the menu for the first time, although this is described in detail in a later section. Do not worry if you have to press keys whose function you are not familiar with, simply follow the instructions step by step. We describe the menu in detail in Section 6.

Note: Various languages are available for the dialog with your instrument and can be selected in the menu. You will find further details on language selection in Section 6.23.



Press the «On/Off» key to switch the instrument on.

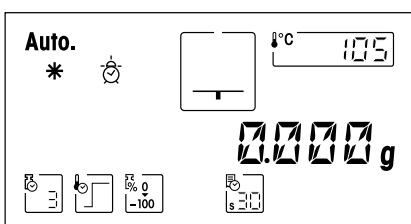

After it has been switched on, the instrument performs a self-test. Wait until the display shown opposite appears.

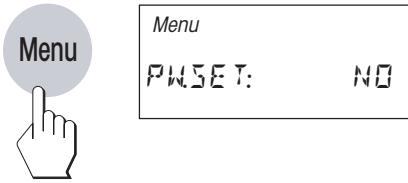

Press the «Menu» key. You are now already in the menu.

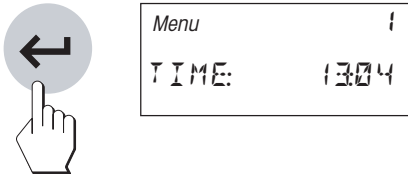

Press the «Accept entry» or «Menu» key repeatedly until the display shown opposite for entry of the time appears.

Important: Do not press any other key, otherwise you could possibly change the factory settings of your instrument!

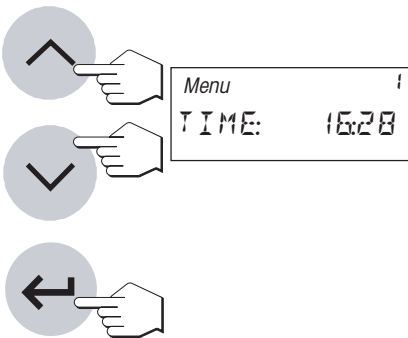

Use the «Scroll up» and «Scroll down» keys to set the time (00:00–23:59). By pressing and holding the keys you can accelerate the change in the time. Confirm your setting with the «Accept entry» key. The instrument stores the time.

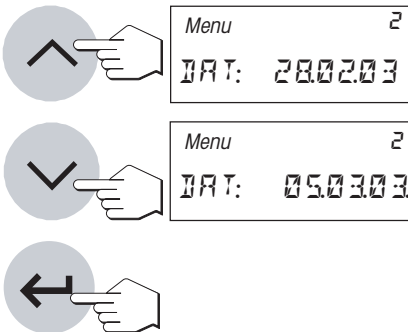

After confirmation of the time, the display for entry of the current date appears. Use the «Scroll up» and «Scroll down» keys to set the date in the format “Day – Month – Year” (DD.MM.YY). By pressing and holding the keys you can accelerate the change in the date. Confirm your entry with the «Accept entry» key and the instrument stores the date.

Note: With US English as the dialog language, the following applies to entry of the date format “Month – Day – Year” (MM/DD/YY).

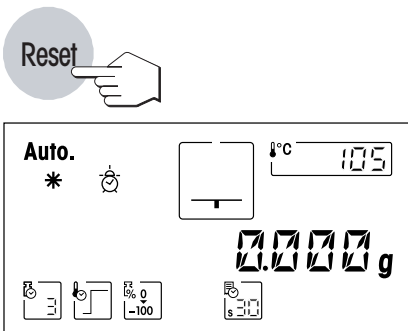

This completes your entry of the date and time, and you can now quit the menu by pressing the «Reset» key. Your settings are stored and remain so even in the event of a power failure. The Moisture Analyzer is now ready for your first measurement.

2.6 Your first measurement

After you have successfully put your new Moisture Analyzer into operation for the first time, you can immediately perform your first measurement. In doing so, you will become familiar with the instrument and the status display and at the same time perform a function check.

Please use the specimen sample supplied for your first measurement. This sample is an absorbent glass fiber filter. During your first measurement, the instrument operates with the factory settings.



Your Moisture Analyzer has a novel graphical status display (User guide) which you will become acquainted with in this section. The status display informs you continuously about the current status of the instrument and prompts you to execute the next operating step (shown flashing).



Switch the instrument on with the «On/Off» key.

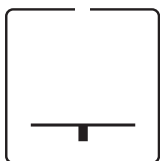

Initial status with closed automatic sample chamber.



Press the «Open/close auto sample chamber» key and ...

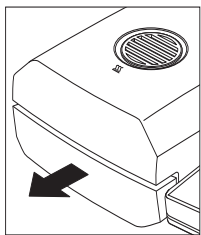

... the motorized, automatic sample chamber opens.



Always ensure **sufficient free space in front of the instrument** since the emerging automatic sample chamber could knock over objects in its path or push them off the bench.

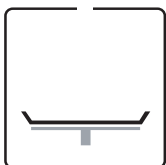

Status: Ready for taring

The status display flashes and prompts you to load the empty sample pan and tare.

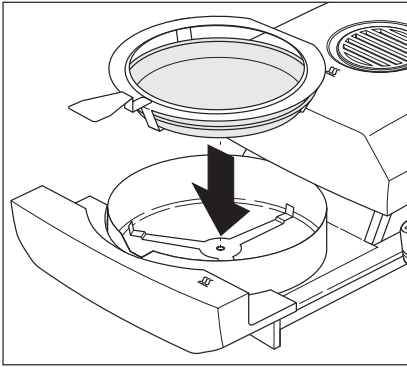

Place the empty sample pan in the sample pan handler (this is possible without tilting the sample pan if you insert this in the pan handler from the side directly below the round flange). Place the sample pan handler in the automatic sample chamber. Ensure that the tongue of the pan handler fits exactly in the slot of the draft shield element. The sample pan must lie flat in the pan holder.

Note: We advise you to work with the sample pan handler at all times. The pan handler is ergonomic, safe and provides protection against possible burns due to the hot sample pan.



Press the «Tare (zero)» key. This sets the balance installed in the Moisture Analyzer to zero. For taring, the automatic sample chamber closes briefly then opens again.



Status: Ready for weighing

After taring, the status display flashes and prompts you to place the sample in the sample pan.

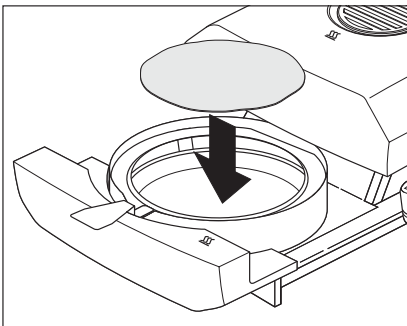

Place the specimen sample in the sample pan.

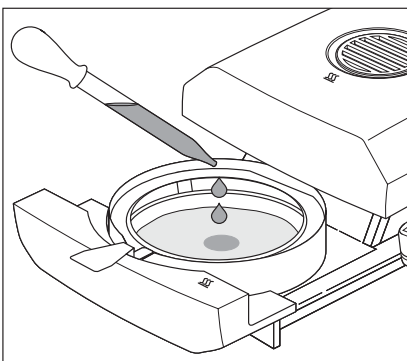

Wet the specimen sample with a few drops of water.

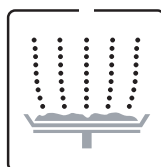

Status: Ready for start

The status display flashes and prompts you to start the drying process.



Press the «Start» key and ...

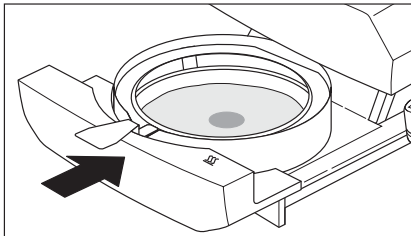

... the motorized, automatic sample chamber closes. The instrument starts the drying and measurement.

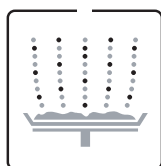

Status: Drying and measurement

You can follow the drying and measurement process in the display:

- The status display uses rising bubbles to symbolize the drying process.
- The current temperature in the heating module is displayed as well as the elapsed drying time and the current drying value.
- Further, the display shows information on the selected settings. You will find additional information on the meaning of the displays and the various setting possibilities in Section 4. If your instrument has a built-in printer, the measurement results will be printed out continually (at intervals of 30 seconds).

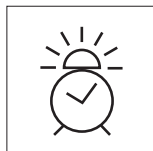
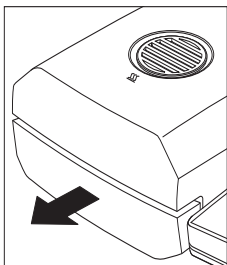
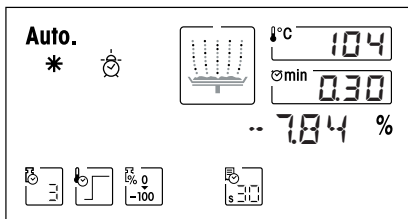

At the end of the drying time, an audio signal sounds and the sample chamber is automatically opened.



Warning: Sample pan and sample are still hot!

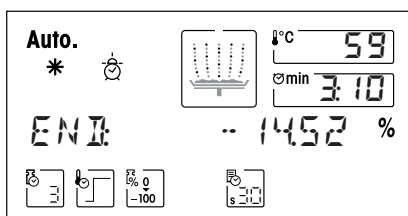

You can now read off the **moisture content** of your sample in the display.

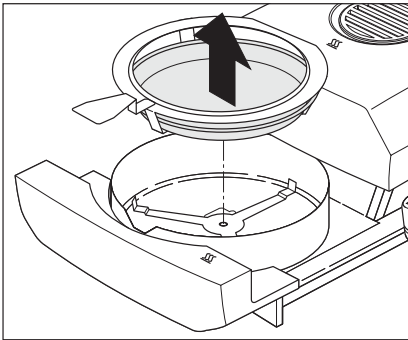

Carefully remove the sample pan handler from the automatic sample chamber.



Warning: As the pan and sample may still be hot, you should let these cool down before removing the pan from the handler!

To remove the sample pan from the handler, lift the pan slightly from below and pull it sideways out of the handler (if you no longer need the sample and the pan, you can simply tilt the handler until the pan slides out).



Press the «Reset» key to delete the measurement result from the display. The instrument is now ready for the next measurement. If you do not wish to perform another measurement, press the «Open/close auto sample chamber» key. The automatic sample chamber closes.

Congratulations!

You have just performed your first measurement with your new Moisture Analyzer. In the following section you will find important information on the operating principle of your instrument, its calibration and optimum preparation of your samples.

Notes on the automatic sample chamber

- Before every automatic closure of the automatic sample chamber, an audio signal sounds.
- For reasons of safety, the open automatic sample chamber is automatically closed after 2 minutes. If a weight change occurs or a key is pressed during this time, the 2 minute period starts over again.

3 How to obtain the best results

Following your first practical work with the Moisture Analyzer, in this Section you will find important information on how to obtain optimum results. You will discover what parameters influence the measurement process and how you can match the instrument optimally to your particular measurement task.

3.1 Measurement principle of the Halogen Moisture Analyzer

Your instrument performs measurements based on the **thermogravimetric principle**, i.e. the moisture is determined from the weight loss of a sample dried by heating.

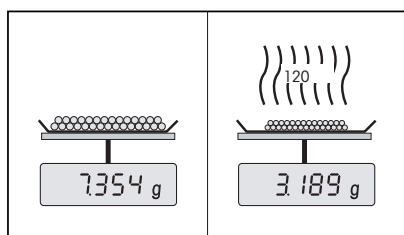

In principle, your instrument thus comprises two instruments: a precision balance and a heating module. In contrast to other thermogravimetric methods (drying oven, infrared, microwave), the Halogen Moisture Analyzer operates with a halogen heating module. This ensures fast heating of the sample and thus guarantees rapid availability of the measurement results.

Irrespective of the measurement method, the quality of the measurement results stands or falls by the **preparation of the sample** and **a correct choice of the important measurement parameters**:



- Sample size
- Drying temperature
- Switchoff mode
- Drying time

Inappropriate setting of these parameters can cause the results to be incorrect or misleading. For this reason, check that the results for each type of sample are what might reasonably be expected.

You will find detailed information on the relationships between these parameters in the application brochure for moisture determination (see Section 9.4), enclosed to your instrument.

In practice, however, not only the quality of the measurement results, but also the **speed of the measurement process** is important. Thanks to its drying principle (with the heat generated by a halogen radiator), the Halogen Moisture Analyzer is very fast. You can increase the speed even further through optimum setting of the instrument.

The **optimum drying temperature and the drying time** are dependent on the nature and size of the sample and on the desired accuracy of the measurement results. These can be determined only by experiment. The Halogen Moisture Analyzer supports you in this task: It offers **automatic performance and result recording of test measurements**. The ideal settings can quickly be determined with **AutoMet** (see Section 4.12).

3.2 Notes on adjustment of the balance and the heating module

You should adjust your Moisture Analyzer regularly (e.g. every six months) if this is stipulated by your quality assurance system (e.g. GLP, GMP, ISO 9001).

The balance and the integral heating module in your instrument can be adjusted using the appropriate accessories (see Section 9.9). The heating module and balance can also be tested (to check the adjustment). The operator can define a test weight or the test temperature, together with permissible tolerances for this test. A test report is printed out showing the test result as "Passed" or "Failed" (see Section 6.3 and 6.5).

By adjusting the heating module you can ensure comparability with results from other instruments of the same design. This is done by using an appropriate thermometer, which is provided in the form of a temperature adjustment set with calibration certificate (see Section 9.9). This adjustment set comprises a black plate with a thermometer, which allows a reproducible adjustment of the heating module.

A Moisture Analyzer is typically used in place of or in addition to the oven method. In an oven heat energy is transferred by the flow of air, which establishes an equilibrium between the sample temperature and the ambient temperature. This is not the case in a Moisture Analyzer. The actual sample temperature primarily depends on the specific absorption properties of the sample ("dark" samples absorb more heat), which can change during the measurement process. There can also be differences between the temperature at the surface of the sample and the temperature inside the sample. The heat output is therefore not dependent on the true sample temperature but instead is regulated by a temperature sensor underneath the halogen heating module.

For the reasons explained above, the temperature setting on the instrument will therefore deviate to the true sample temperature. By regularly adjusting the heating module, you will ensure a consistent and reproducible heat output for the entire lifetime of your instrument.

Note: METTLER TOLEDO offers an adjustment service – please contact your local dealer.

- If you also use your instrument as a high precision lab balance, you should adjust the balance at regular intervals.
- If you replace the heating module, you must adjust it using the temperature adjustment set, which is available as an accessory.

The procedure for adjusting the balance and heating module is described in Section 6.

3.3 Optimum sample preparation

Preparation of the sample is decisive for the speed of the measurement process and the quality of the measurement results.

Please note the following **basic rules** for the preparation of your sample:

The amount of sample you select should be as small as possible and only as large as necessary

Excessive amounts of sample require more time for drying and thus prolong the measurement process. If the amount of sample is too small, the measurement result may possibly not be representative. The following always holds: The greater the inhomogeneity of the sample, the larger the amount of sample needed to obtain a repeatable result (please see also the list in Section 9.1).

Distribute the sample evenly over the sample pan

You thus increase the surface area of the sample and facilitate heat absorption. The base of the pan should be evenly covered.

With liquid, fat-containing, melting and highly reflecting samples, you should cover the sample with the glass fiber filter available as optional equipment (HA-F1 214464, see Section 9.9). This also applies to samples which form a skin on their surface when heated. The glass fiber filter ensures even and rapid heat distribution and prevents the formation of a skin impervious to moisture on the sample surface.

3.4 Further information on moisture determination

You will find further information on the moisture determination, the importance of the parameters and the preparation of the samples in the **Application Brochure** "Methods of moisture content determination" dealing with moisture determination (see Section 9.4).

Useful tips and a variety of example methods (comparison between Halogen Moisture Analyzer results and the oven method) can be downloaded from **www.mt.com/moisture**.

If you require information on specific applications, your METTLER TOLEDO dealer will be pleased to help you.



Moisture determination applications must be optimized and validated by the user according to local regulations. Application-specific data provided by METTLER TOLEDO is intended for guidance only.

4 Practical application of your Moisture Analyzer

In this Section we introduce you to the wide range of setting possibilities of your Moisture Analyzer and offer information and tips for optimum setting of the parameters.

4.1 Operating principles

You already performed your first measurement in Section 2. This measurement was carried out using the factory settings. However, your instrument offers a number of setting possibilities to match the measurement process to your specific requirements. For instance, you can preselect the drying temperature, the type of result display and many other parameters.

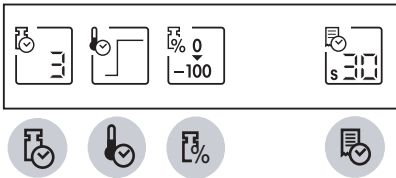

Settings are made using the function keys. These keys are right at the top of the keypad, directly below the display. The setting you select appears in the display directly above the associated key.

You will learn the available setting possibilities and the function keys in detail in the following Sections. Further, you will also discover how to set the drying temperature and the drying time and how to work with the weighing-in aid. Finally, you will perform a complete measurement with the specific settings for your sample.

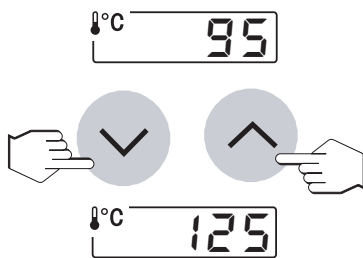

Numeric entries:

With some settings (e.g. the drying temperature), **numeric entries** are required. There are two different ways of entering numerical values:

You can change the flashing displayed value with the «Scroll up» or «Scroll down» key or ...

... you can key in the new value directly with the numeric keypad.

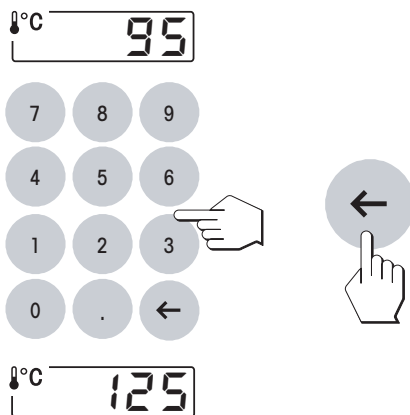

You can remove wrong numbers with the «Delete» key.

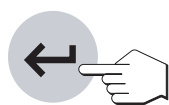

As soon as you have entered the desired value, press the «Accept entry» key. The value will be stored.

Preliminary information on the methods:

All settings for a sample which you will learn in the following Sections can be collected in a so-called "Method". You have 40 methods freely available thus giving you the possibility of defining a method for a particular sample and recalling it at any time. This eases the work load considerably as each time you switch to a different type of sample there is no need to repeat all the parameter settings. The methods are retained when the instrument is switched off. You will find information on the compilation and use of methods in Section 5.

4.2 Selecting the drying program

This function key offers you four different drying programs for optimum matching of the drying characteristics to the sample used.



Each time this key is pressed, the next program appears. After the fourth and last program, the first reappears in the display. As soon as you have selected the desired program, the setting is active and you do not have to confirm or store it.



Standard drying

This **drying program** is set in the factory and is suitable for most samples. The sample is heated to the drying temperature (set temperature) and held constant at this temperature.



Rapid drying

This program is primarily suitable for **samples with a moisture content over 30%**. Following the start, the selected temperature is **exceeded** by 40% for 3 minutes to compensate the cooling due to vaporization and accelerate the drying process. The drying temperature is then lowered to the set value and maintained. You will find details on how to enter the drying temperature in the Section 4.3.



Gentle drying

This program is suitable for the gentle drying of **substances which tend to form a skin** (e.g. substances containing sugar). With this program the temperature is continuously increased and attains the selected drying temperature **only after the elapse** of the so-called "ramp time". The "ramp", i.e. the time that should elapse between the start of drying and attainment of the final temperature is preselectable. The setting of the "ramp" is described in the next Section 4.3.



Step drying

This program is suitable for the drying of **substances composed of several components** which vaporize at different temperatures (e.g. ethereal oils). With this program drying is performed **stepwise**, i.e. the sample is preheated to a particular temperature (1st step) and kept at this temperature for the selected time (hold time).

The temperature is then increased to the next value (2nd step) and again maintained for a certain time. Finally, the temperature is raised to the preselected drying temperature (set temperature) and held constant at this value until the end of drying. With this program you can preselect the temperature and time for each step. These settings are described in the Section 4.3. If only one step is needed, the time of step 2 must be set to 0.

Step drying can also be useful for the **rapid determination of substances with a high moisture content**. Here, the 1st step is set higher than the final temperature to compensate the cooling due to vaporization.

4.3 Setting the drying temperature



After pressing this key you can enter the drying temperature (set temperature).

The type of entry depends on the selected drying program (see Section 4.2). If you have selected one of the programs "Standard drying" or "Rapid drying", you need enter only the drying temperature. For the two programs "Gentle drying" and "Step drying", additional entries are required to define the ramp or the steps. The different entry procedures are described below.

Note: The admissible input range for temperatures is 40 °C–200 °C.

Selecting drying temperature for standard drying and rapid drying

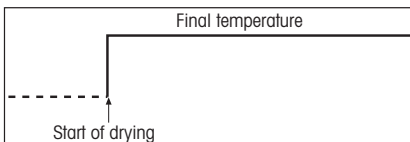

You need enter only the desired final temperature.



°C 125

Press the «Drying temperature» key and enter the desired drying temperature (see Section 4.1).

- either with the «Scroll up» and «Scroll down» keys or
- directly via the numeric keypad

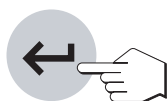

Press the «Accept entry» key.

Selecting drying temperature for gentle drying

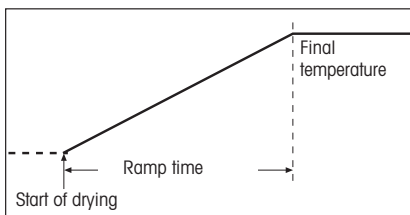

For this temperature program you first define the so-called "ramp", i.e. the time that should elapse between the start of drying and attainment of the final temperature. You then select the drying temperature (final temperature). The ramp is started once the temperature reaches 50 °C.



Press the «Drying temperature» key.



Entering the ramp time:

The instrument prompts you to define the ramp time. In the factory the ramp time is set to 3 minutes.



Enter the desired value.



Press the «Accept entry» key.

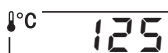

Entering the drying temperature:

The instrument now prompts you to enter the drying temperature (final temperature). Enter the desired temperature (e.g. 125 °C).



Press the «Accept entry» key.

Selecting drying temperatures for step drying

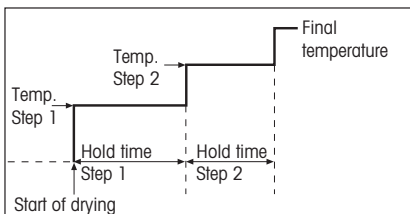

For this temperature program you define the temperature and the hold time for each step.



Press the «Drying temperature» key.

The LCD display shows the text "TEMP. 1" on the left and the number "100" on the right.**Entering the drying temperature and hold time for the first step:**

The instrument prompts you to define the temperature for the first step. Enter the desired temperature.

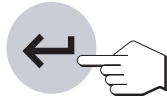

Press the «Accept entry» key.

The LCD display shows the text "TIME. 1" on the left and the time "4:30" on the right.

The instrument now prompts you to enter the hold time for the first step. Enter the desired time.

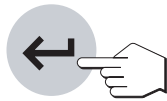

Press the «Accept entry» key.

The LCD display shows the text "TEMP. 2" on the left and the number "125" on the right.**Entering the drying temperature and hold time for the second step:**

The instrument now requests entry of the temperature for the second step. Enter the desired temperature.

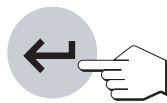

Press the «Accept entry» key.

The LCD display shows the text "TIME. 2" on the left and the time "3:00" on the right.

Define the hold time for the second step.

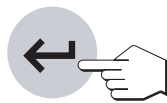

Press the «Accept entry» key.

The LCD display shows the text "°C" on the left and the number "160" on the right.**Entering the final temperature:**

Finally, you enter the desired final temperature.

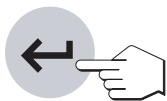

Press the «Accept entry» key.

Temperature limitation

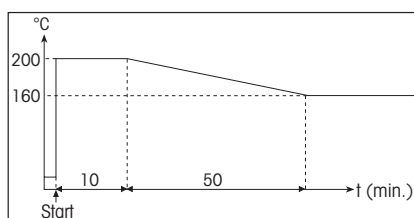

With regard to high temperatures, the moisture analyzer has several protective mechanisms that work independently of each other:

- At temperatures above 160 °C a time limit becomes active. The higher the temperature, the shorter the time until the instrument starts to lower the temperature (envelope curve, see illustration opposite). **Note:** If necessary, this time-controlled lowering of the temperature can be deactivated in the Methods menu (Section 5.4). If deactivated, temperatures from 160 °C - 200 °C are available without time limitation.
- A temperature switch independent of the normal black temperature sensor over the sample (see Section 7.1) is triggered when it detects exceptionally high temperatures. This situation could arise, for example, if the sample begins to burn or the heating module adjustment is defective. If this happens, the heating module is tripped out by a mechanical switch, and the instrument cannot be restarted. Please refer to Section 8.3 for troubleshooting.

When working with temperatures over 180 °C we recommend that you always wait 2 - 3 minutes between individual measurements, in order to ensure good reproducibility of the readings.

Note: A measurement cannot be started until the drying temperature is higher than the temperature in the measuring room. This avoids a false start (Error 10, Section 8.2).

4.4 Selecting the switch-off criterion

This function key offers you different switch-off criteria. A switch-off criterion defines when the instrument should end the drying. Switch-off criteria save you having to keep checking your watch and stopping the drying manually.

The following settings can be selected for the switch-off criterion:

- “Weight loss per unit of time” (5 settings)
- “Free switch-off criterion” (if activated in the Methods menu, Section 5.4)
- “Manual switch-off”
- “Timed switch-off”
- “Test measurement” for determination of the suitable switch-off criterion

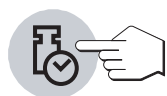

Weight loss per unit of time

This switch-off criterion is based on a weight loss per unit of time. As soon as the mean weight loss is less than a preset value during a specified time, the instrument considers drying as complete and automatically discontinues the measurement process. During the drying, the time display shows you how long the measurement process has been in progress. The switch-off criterion is inactive during the first 30 sec. You will find additional information in Section 9.5.



The following 5 settings are available:

This setting is suitable for samples which dry very quickly (surface moisture) or for (relatively inaccurate) fast measurements to determine a trend.



This setting is suitable for quick drying samples.



This is the **factory setting**. It is suitable for most types of samples.



This setting is suitable for samples which dry moderately quickly.



This setting is suitable for samples which dry very slowly (trapped moisture, skin formation).

Note: If you do not know the behavior of a sample, perform a test measurement to determine the suitable switch-off criterion. The procedure is described later in this section under the title "Test measurement".

Free switch-off criterion

This setting possibility is available only if you have activated it in the Methods menu (Section 5.4). There is one free switch-off criterion available for each method. The free switch-off criterion is based on a user-defined mean weight loss per unit of time.



You will find information on the activation and definition of the individual switch-off criterion in Sections 5.4.1 and 9.5.

Note: The free switch-off criterion can be determined automatically with **AutoMet** (Section 4.12).

Manual

With this switch-off criterion the measurement process continues until you stop it with the «Stop» key.



The time shown in the display tells you how long the current measurement has been in progress.

Timed switch-off

With this switch-off criterion the measurement lasts until the preset drying time has elapsed (the time display provides you with continuous information on the drying time).



If you select this criterion, you must then enter the desired **drying time** as follows:



Press the «Drying time» key.

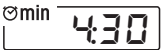

Enter the desired drying time.

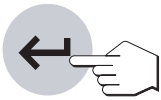

Press the «Accept entry» key.

Test measurement



Press Ψ to perform a test measurement which will help you to determine suitable switch-off criteria (Section 4.11).

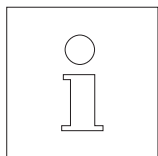

Using **AutoMet** test measurement is a quick way of determining a Halogen Moisture Analyzer method that corresponds most closely to your reference value (target value) (Section 4.12).

4.5 Selecting the display mode

With this function key you can select the desired type of result display. You also define what values are printed on the records.

The following display modes are available:

Moisture content



The moisture content of the sample is displayed (and printed out) as a percentage of the wet weight (= $ww = \text{initial weight} = 100\%$). This is the **factory setting**.

When the results are printed out, the moisture content is marked by “%MC” (**M**oisture **C**ontent) (e.g. -11.35 %MC) and shown as a negative value.

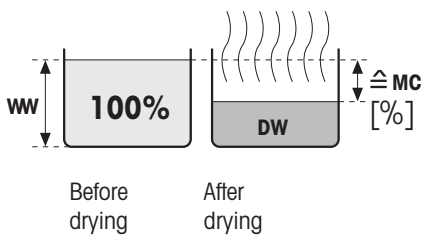

$$MC [0 \dots 100\%] = - \frac{\text{Wet weight } WW - \text{Dry weight } DW}{\text{Wet weight } WW} * 100\%$$

During the drying the current measured value is continuously displayed in percent.

Dry content



The dry content of the sample is displayed (and printed out) as a percentage of the wet weight (= $ww = \text{initial weight} = 100\%$).

When the results are printed out, the dry content is marked by “%DC” (**D**ry **C**ontent) (e.g. 88.65 %DC).

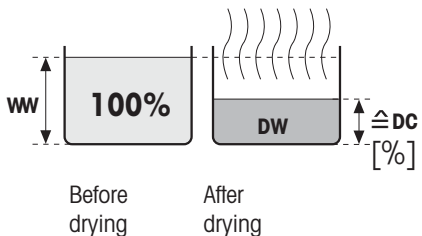

$$DC [100 \dots 0\%] = \frac{\text{Dry weight } DW}{\text{Wet weight } WW} * 100\%$$

During the drying the current measured value is continuously displayed in percent.

Weight in grams



The weight of the sample is displayed (and printed out) in grams. With this setting, the Moisture Analyzer is used as a precision balance.

During the drying the current weight is continuously displayed in grams.

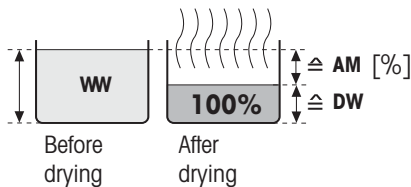

ATRO moisture content

The moisture content of the sample is displayed (and printed out) as a percentage of the dry weight (= DW = final weight = 100%).

When the results are printed out, the ATRO moisture content is marked by “%AM” (ATRO Moisture Content) (e.g. -255.33 %AM) and shown as a negative value

$$AM [0 \dots -1000\%] = - \frac{\text{Wet weight } WW - \text{Dry weight } DW}{\text{Dry weight } DW} * 100\%$$

During the drying, the current measured value is continuously displayed in percent.

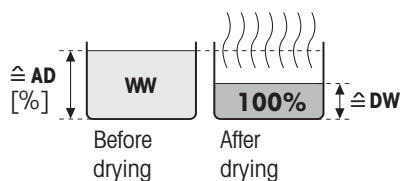

ATRO dry content (Wet weight)

The wet weight of the sample is displayed (and printed out) as a percentage of the dry weight (= DW = final weight = 100%).

When the results are printed out, the ATRO dry content is marked by “%AD” (ATRO Dry Content) (e.g. 312.56 %AD).

$$AD [100 \dots 1000\%] = \frac{\text{Wet weight } WW}{\text{Dry weight } DW} * 100\%$$

During the drying, the current measured value is continuously displayed in percent.

Comment on the ATRO display mode

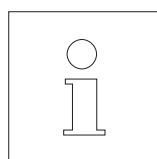

If the current measured value in the ATRO display mode is greater or less than the predefined limit value (i.e. greater than 999.99 %AD or less than -999.99 %AM), a warning beep sounds and the instrument automatically switches the display mode (from %AM to %MC and from %AD to %DC). A display in the ATRO mode is no longer possible in this case, even if you have started your drying operation in the %MC, %DC or “g” (grams) display mode. If your measurement series contains such an inadmissible ATRO measured value, the statistical evaluation (see Section 5.7) will also be performed in the new, automatically selected mode.

4.6 Defining the print interval

One point before we start: This setting possibility is available only if the built-in printer is activated in the menu (see Section 6.15).

The print interval determines the printout frequency of the intermediate results of an ongoing measurement.



The following settings are available under this function key:

Printout at intervals

These 6 settings allow printout of the intermediate results at fixed, preset intervals. You can thus trace the drying process using the printed record. The following print intervals are available:

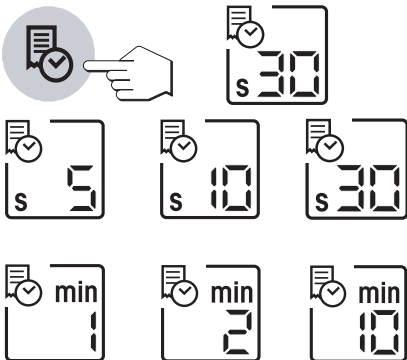

- Printout **every 5 seconds**
- Printout **every 10 seconds**
- Printout **every 30 seconds (factory setting)**
- Printout **every minute**
- Printout **every 2 minutes**
- Printout **every 10 minutes**

Free print interval

This setting possibility is available only if you have activated it in the menu. You will find information on the activation and definition of the free print interval in Section 6.18.



Manual printout

With this setting there is no automatic printout. However, you can print out the intermediate results at any time with the «Print» key.



4.7 Working with the weighing-in aid

The weighing-in aid can be defined for each method and facilitates weighing in of the sample to a preset weight value (target value). This is particularly useful if you require all the samples you wish to process to have same weight in order to improve the repeatability of the measurement results. In addition, the weighing-in aid can be configured so that the drying process cannot be started if the weight of sample is outside the set tolerance. You are therefore compelled to weigh in the correct quantity of sample ("Weighing-in aid active").

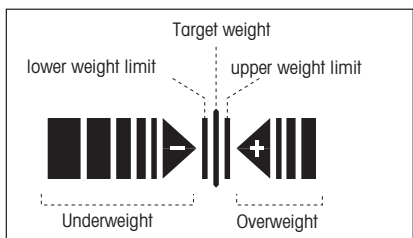

The weighing-in aid in the bottom right corner of the display comprises two opposite facing bars and triangles with a minus or plus symbol.

The weighing-in aid is available only if it has been activated. If the minus or plus symbol is visible after taring, the weighing-in aid is activated.

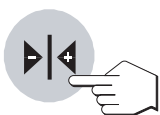
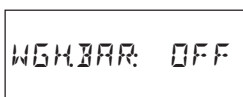

If you want to switch on the weighing-in aid, press the «Target weight (Weighing-in aid)».

In the factory the weighing-in aid is switched off ("OFF").



You can use the «Scroll up» and «Scroll down» keys to select either the "Weighing-in aid passive" or "Weighing-in aid aktive" setting.

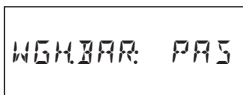

If the "Weighing-in aid passive" setting is selected, the weighing-in aid is switched on and a target weight can be defined. With this setting the drying process can be started even if the sample weight lies outside the set limits. These are defined by the target weight and the sample weight tolerance as a % of the target weight (see below).

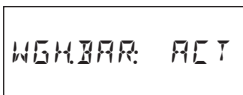

With the weighing-in aid set at "Weighing-in aid active" the drying process cannot be started if the sample weight is outside the set limits. You are therefore compelled to weigh in the correct quantity of sample, and are prevented from inadvertently starting the drying process with the wrong sample weight.

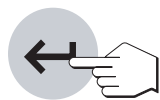

After selecting the desired mode for the weighing-in aid, confirm your selection by pressing the «Accept entry» key.

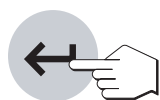
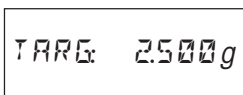

Enter the desired target weight (0.100 g to 80.000 g) via the numeric keypad (**Factory setting: 2.5 g**) and confirm with the «Accept entry» key.

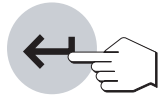

You can now use the «Scroll up» and «Scroll down» keys (or the numeric keypad) to define the sample weight tolerance in the range 1% to 25%. The sample weight tolerance (**Factory setting: 10%**) defines the lower and upper sample weight limits. Confirm your entry with the «Accept entry» key.

The symbols of the weighing-in aid appear in the display after you have tared the balance.

How the weighing-in aid operates

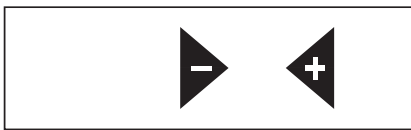

Before the start of weighing (standby mode)

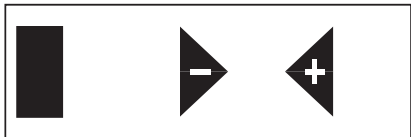

Start of weighing (sample weight too low)



Lower weight limit reached (sample weight in tolerance range). The status display (user guide) indicates with its flashing 'rising bubble' graphic that the instrument is ready to run.

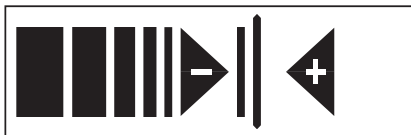

Target weight reached (sample weight in tolerance range). The status display (user guide) indicates with its flashing 'rising bubble' graphic that the instrument is ready to run.

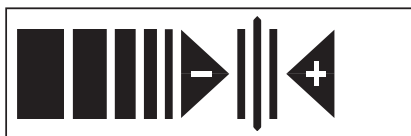

Upper weight limit reached (sample weight in tolerance range). The status display (user guide) indicates with its flashing 'rising bubble' graphic that the instrument is ready to run.

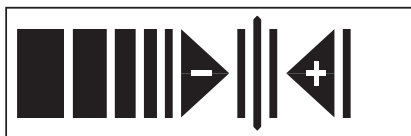

Upper weight limit exceeded (sample weight too high)

After initiation of the measurement with the «Start» key, the bars of the weighing-in aid disappear.

4.8 Comment lines

You can include up to 4 comment lines in your measurement records, e.g. in order to enter different sample IDs. These comment lines are called C1 to C4 (see Section 6.20). The alphanumeric comment lines can be up to 20 characters in length and are method specific. To enter a comment:

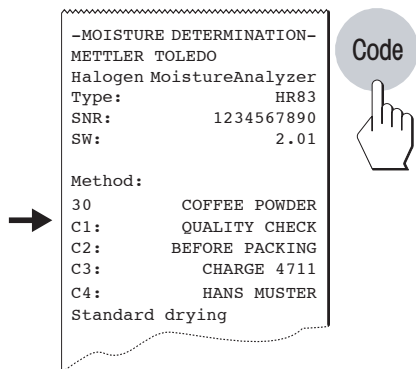

Press the «Code» key. The input field for the record header comment appears. The name of the comment line (C1 to C4) appears on the display in input mode.

If a comment has been entered previously, it appears in the display. The procedure for changing existing comments is described later. If you want to enter a new comment, **or completely overwrite an old one**, proceed as follows:



Press the «A...Z» key. A flashing "A" appears at the first input position on the extreme left and signals that the instrument is ready for your entry.

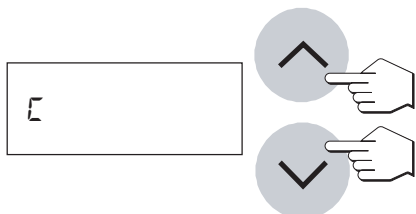

You can now use the «Scroll up» and «Scroll down» keys to select the first letter of the comment (uppercase letters only) or a special character (+, -, etc.).



Confirm your selection with the «A...Z» key. The flashing "A" again appears, but at the second position.

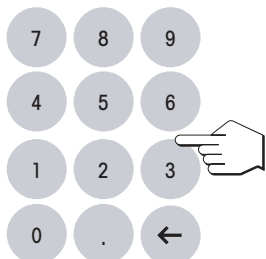

Enter a further character of the desired comment as described above. Numbers can be entered via the numeric keypad.

Notes

- A space is symbolized by an underline character " _".
- You can remove wrong characters with the «Delete» key and then correct your entry.

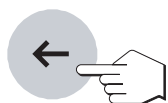

Changing a comment line

If you want to change an existing comment (e.g. increasing a sample number, entering a serial number), proceed as follows:



Press the «Code» key. The most recently saved comment appears (provided that it has not been automatically cleared, see Section 6.20).

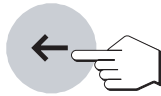

Press the «Delete» key. A flashing dash appears after the last character, indicating input mode.



You can then add additional characters by pressing the «A...Z» key or a number key on the numeric keypad.

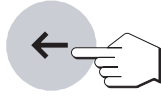

By pressing the «Delete» key a second time you can delete the last character. The second last character flashes and can be changed using the numeric keypad or the «Scroll up» and «Scroll down» keys, or confirmed with the «A...Z» key. Further characters can then be added as described above.

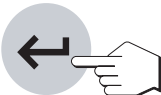

As soon as you have finished entering your comment, press the «Accept entry» key to quit the input mode (the flashing character will also be accepted). From now on your comment will be automatically printed out on each measurement record.

Defining different comment lines



Press the «Code» key once to enter comment C1. Press the «Code» key repeatedly to enter comments C2, C3 and C4.

Automatic clearing of comment lines after each measurement

In the menu you can define which comment lines are to be cleared automatically after each measurement (see Section 6.20).

Displaying comment line C1 during measurement



By pressing the «Code» key you can display the current comment C1 for 3 seconds during the drying process.

Note: Comment lines C1 to C4 are method specific. A general additional output text for all methods (e.g. company name and department) can be defined in the menu (Section 6.16).

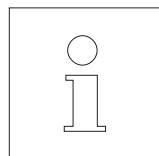

The comment lines C1 to C4 can optionally be entered using a Barcode Reader (Section 9.3).

4.9 Information on the measurement record

If your instrument has a built-in printer and this is activated in the menu, the intermediate values will be printed out at the preselected intervals and the final result recorded on completion of the measurement.

The extent of detail of the record depend on the settings selected in the menu (see Section 6.17). The illustrations below show examples of a standard length measurement record (factory setting) and an extended measurement record.

Structure of the standard-length measurement record

The standard-length measurement record contains the following data (from top to bottom):

```

A  ~~~~~
A  -MOISTURE DETERMINATION-
B  COFFEE LTD
C  PRODUCTION XY

D  METTLER TOLEDO
   Halogen MoistureAnalyzer
E  Type:                HR83
F  SNR:                 1234567890
G  SW:                  2.01

H  Method:
   38      COFFEE POWDER
I  C1:      QUALITY CHECK
   C2:      BEFORE PACKING
   C3:      CHARGE 4711
   C4:      HANS MUSTER
J  Switchoff mode  F
   1 mg /   35 sec
K  Standard drying
L  Drying temp.   105 °C
M  Disp.mode     0...-100 %MC
N  Start weight  2.507 g

O  1:00 min     -2.51 %MC
   2:00 min     -3.39 %MC
   3:00 min     -3.71 %MC

P  Total time    3:19 min
Q  Dry weight   2.412 g
R  End result   -3.79 %MC

S  ---30.06.03---15.14---

```

- A** Record title
- B** Company name text (see Section 6.16)
- C** Department name text (see Section 6.16)
- D** Manufacturer and Designation of the instrument
- E** Type of the instrument
- F** Serial number of the instrument
- G** Version number of the software
- H** Number and Name of the selected method (see Section 5)
- I** Comment lines (e.g. sample ID) if code 1, 2, 3 or 4 was entered (see Section 4.8)
- J** Selected switch-off criterion (or set drying time)
- K** Selected drying program
- L** Drying temperature (set temperature)
- M** Selected display mode
- N** Sample weight at start of drying
- O** Measured value at each print interval (the number of recorded measured values depends on the selected print interval and the measurement time)
- P** Total time of drying
- Q** Dry weight of the sample in grams
- R** Final result in the selected display mode
- S** Date and time at the end of the measurement

Notes

- You will find information on the dimensions of the results (%**MC**, %**DC**, %**AM** and %**AD**) in Section 4.5.
- Depending on the settings in the Methods menu (Section 5.4), the data printout can contain other information, which is described in the relevant sections (Section 5.4.1 - 5.4.6).

Structure of the extended measurement record

In addition to the data provided in the standard-length measurement records (see Section 4.9), the extended records contain the following information:

```

%%%%%%%%%%%%%%%%%%%%%%%%%%%%%%%%%%%%%%%%%%%%%%%%%%%%%%%%%%%%%%%%%%%%%%%%
-MOISTURE DETERMINATION-

COFFEE LTD
PRODUCTION XY

METTLER TOLEDO
Halogen MoistureAnalyzer
Type:                HR83
SNR:                 1234567890
SW:                  2.01
A Balance Adjustm.   52
B Dryer Unit Adjustm. 23
C Measurement        12
Method:
38      COFFEE POWDER
C1:     QUALITY CHECK
C2:     BEFORE PACKING
C3:     CHARGE 4711
C4:     HANS MUSTER
Switchoff mode F
          1 mg / 35 sec
Gentle drying
D Ramp time         1:00 min
  Drying temp.     105 °C
  Disp.mode        0...-100 %MC
  Start weight     2.507 g

          1:00 min    -1.19 %MC
          2:00 min    -2.94 %MC
          3:00 min    -3.65 %MC
          4:00 min    -3.77 %MC

Total time         4:12 min
Dry weight         2.412 g
E Moisture         0.095 g
F Signature:

.....
----30.06.03----15.18----
    
```

- A** Identification (consecutive number) of the balance adjustment, allows assignment of the measurement record to the appropriate adjustment record
- B** Identification (consecutive number) of the heating module adjustment, allows assignment of the measurement record to the appropriate adjustment record
- C** Consecutive number of the measurement (corresponds to the sample size or the number of measurement results in the statistics)
- D** Ramp time (time between the start of drying and attainment of the final temperature)
- E** Moisture content
- F** Field for signature of the person who performed the Moisture determination.

Note: Depending on the settings in the Methods menu (Section 5.4), the data printout can contain other information, which is described in the relevant sections (Section 5.4.1 - 5.4.6).



```

0:20 min    -0.73 %MC
0:24 min    --->
0:28 min    <---
0:30 min    -0.86 %MC
    
```

Special events are recorded in the measurement record as follows:

In **the manual operating mode of the automatic sample chamber**, the **sample chamber** was opened and closed during the drying operation. When the automatic sample chamber is open, drying is interrupted and then continued when the chamber is closed.

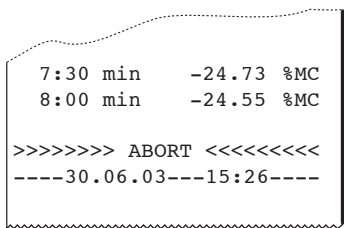

The «Reset» key has been pressed. The drying process is **aborted** and the measurement result at the time of the abort is not evaluated as it could be wrong.

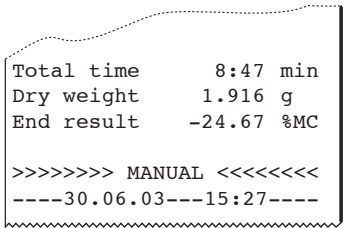

The drying process has been **stopped manually** with the «Stop» key. The elapsed drying time at the time of the stop and the measurement result are recorded. Please note that with manual stop the final result only shows the moisture content after the manually determined total duration.

4.10 Performing a measurement

You are now familiar with all the parameters of your Moisture Analyzer and have defined all values for your sample. The instrument is now ready for the determination of your own samples. In this Section you will learn how to perform measurements, print out the measurement results and stop the measurement process.



Switch the instrument on with «On/Off» key.

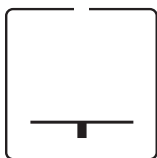

The status display (User guide) symbolizes the initial status of the instrument when the automatic sample chamber is closed.



Press the «Open/close auto sample chamber» key and ...

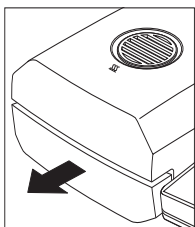

... the automatic sample chamber opens.



Always ensure **sufficient free space in front of the instrument** since the emerging sample chamber could knock over objects in its path or push them off the bench.



The status display (User guide) now prompts you to load the empty sample pan and tare the balance.

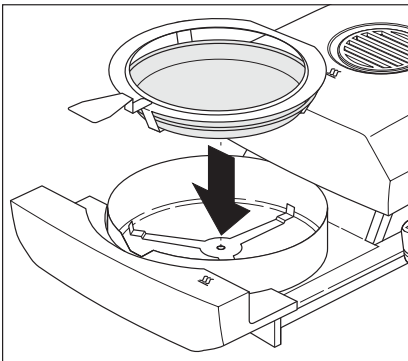

Position the empty sample pan in the sample pan handler. Place the sample pan handler in the automatic sample chamber. Ensure that the tongue of the sample pan handler lies exactly in the slot of the draft shield element. The pan must lie flat in the pan holder.

Note: We advise you to work with the sample pan handler at all times. The pan handler is ergonomic, safe and provides protection against burns due to the hot sample pan.



Press the «Tare (zero)» key. This sets the integral balance to zero. For taring the automatic sample chamber closes briefly then opens again.

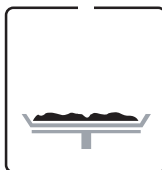

Following taring, the status display prompts you to add the sample to the sample pan.

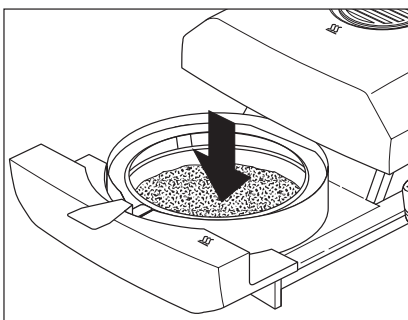

Add the sample to the sample pan. If you are working with the weighing-in aid, weigh the sample (minimum weight 0.1 g) using the bar display as explained in the Section 4.7.

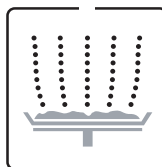

The status display now prompts you to start the drying process.



Press the «Start» key and ...

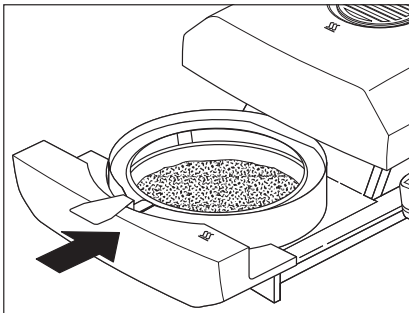

... the motorized, automatic sample chamber closes. The instrument starts the drying and measurement.

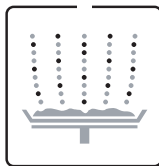

You can follow the measurement process in the display: The status display uses ascending bubbles to symbolize the drying process with the following values being continuously updated and displayed:

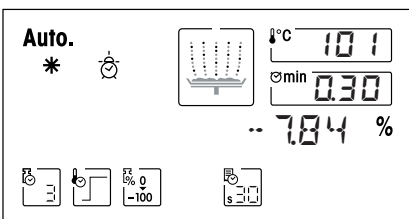

- **current temperature** in the heating module
Note: You can use the «Drying temperature» key to display the preselected drying temperature (current set temperature) for 2 seconds.
- **elapsed time** since the start of the measurement process
Note: If you have selected the switch-off criterion "Timed switch-off", the elapsed drying time will be displayed. You can display the preselected drying time for 2 seconds with the «Drying time» key.
- **current result** in the preselected display mode
 You can select a different display mode with the function key at any time even during the measurement.



If your instrument has the built-in printer and this has been activated, the measured values are printed out at the preselected intervals. You can use the «Print» key to output the intermediate result manually on the printer at any time. The units of the intermediate result are as defined in the preselected display mode and can therefore be changed during the drying process by pressing the «Display mode» function key. You will find an explanation of the measurement record in the Section 4.9.

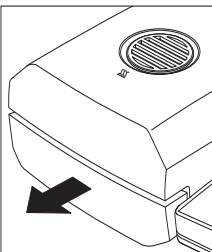

As soon as the preselected switch-off criterion is met (or the selected drying time has elapsed), an audio signal sounds. The measurement process is now ended and the sample chamber automatically opens.



Warning: Pan and sample may still be hot! Allow them to cool before you remove the pan from the handler!



Note: You can also manually **stop** the measurement process **prematurely** at any time by pressing the «Stop» key. With a measurement time of minimum 30 seconds or more, the result will be printed out at the time of the stop, transferred to the journal (see Section 5.6) and incorporated in the statistics (see Section 5.7). If you **abort** a measurement process earlier or by using the «Reset» key, the measurement result will not be displayed and also not transferred to the journal or incorporated in the statistics.

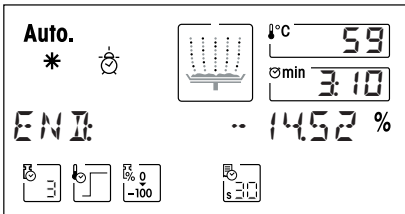

You can now read off the measurement result in the display. You will find information on the interpretation of the measurement results in Section 9.1. The result and time display remain at their final values, whereas the temperature continues to be updated.

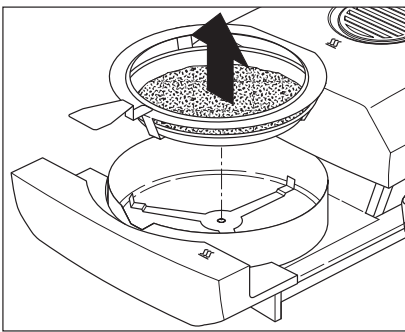

Carefully remove the sample pan handler from the automatic sample chamber.



Press the «Reset» key to delete the final result and the time display. The display can also be cleared with the «Tare (zero)» key. This facilitates efficient working if the next empty sample vessel has already been loaded.



If you do not wish to perform another measurement, switch the instrument off with the «On/Off» key. After this operation, the sample chamber automatically closes.

4.11 Test measurement

You can use this function only if your instrument is fitted with a printer!



```

--- TEST MEASUREMENT ---
METTLER TOLEDO
Halogen MoistureAnalyzer
Type:                HR83
SNR:                 1234567890
SW:                  2.01

Method:
34                   TOBACCO
C1:                  HAVANNA
C2:                  CHARGE 4711
C3:                  SYSTEM B
C4:                  H.MUSTER
Switchoff mode      T
Standard drying
Drying temp.        120 °C
Disp.mode           0...-100 %MC
Start weight        2.543 g

0:00 min            -0.00 %MC
0:30 min            -1.96 %MC

4:30 min            -13.80 %MC
5:30 min            -14.39 %MC

Switchoff mode      1
Time                5:37 min
Result              -15.14 %MC
                   -2.158 g

7:00 min            -15.28 %MC
7:30 min            -15.42 %MC

Switchoff mode      2
Time                7:42 min
Result              -15.81 %MC
                   -2.141 g

11:00 min           -16.56 %MC

Switchoff mode      5
Time                11:22 min
Result              -16.91 %MC
                   -2.113 g

Total time          12:33 min
Dry weight          2.108 g
End result          -17.11 %MC

>>>>>>> MANUAL <<<<<<<<
-----30.06.03---15:28-----
    
```

If you wish to work with the switch-off criterion “Weight loss per unit of time” and are not familiar with the behavior of the sample, the test measurement will help you select the suitable setting.

The diagram opposite illustrates the progress of a drying. The points at which the individual switch-off criteria were reached (1–5) are marked.

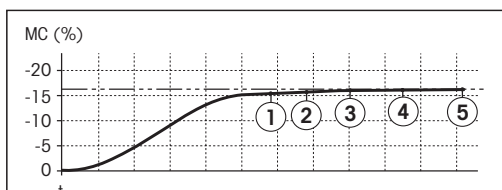

Test measurement procedure

Press “Y” («Switch-off criterion» function key) to perform a test measurement. You perform a test measurement just like any other measurement. You will find further information on how to perform the measurement in Section 4.10.

Printing out the test measurement



During the test measurement a record is printed out which explains exactly when and with what measurement result each switch-off criterion was reached. The test procedure can be ended at any time with the «Stop» key. Automatic switch-off follows after a measurement time of 8 hours.

Notes



- Test measurements are not entered in the journal or the statistics (Sections 5.6 and 5.7).
- Depending on the settings in the Methods menu (Section 5.4), the data printout can contain other information, which is described in the relevant sections (Section 5.4.1 - 5.4.6).

4.12 AutoMet test measurement

Procedure:

Weighing in of the sample

```

----- TEST MEASUREMENT -----
METTLER TOLEDO
Halogen MoistureAnalyzer
Type:                HR83
SNR:                 1234567890
SW:                  2.01

Method:
34                   TOBACCO
C1:                  HAVANNA
C2:                  CHARGE 4711
C3:                  SYSTEM B
C4:                  H.MUSTER

Switchoff mode
Standard drying
Drying temp.        120 °C
Disp.mode 0...-100 %MC
Max. Time           30:00 min
Target              -16.80 %MC
Start weight        2.543 g

      0:00 min      -0.00 %MC
      0:30 min      -1.96 %MC

      7:30 min      -15.28 %MC
      7:30 min      -15.42 %MC

Switchoff mode 2
Time            7:42 min
Result          -15.81 %MC
                -2.141 g

      8:00 min      -16.12 %MC

Switchoff mode 5
Time            11:22 min
Result          -16.91 %MC
                2.113 g

Total time      12:33 min
Dry weight      2.108 g
End result      -17.11 %MC

*****
AutoMet:
Target reached
Time            8:22 min
Switchoff mode F
                1 mg / 75 sec
*****

>>>>>> MANUAL <<<<<<<<
-----30.06.03---15:50-----
    
```

AutoMet test measurement helps you to save time when developing methods. It also enables you to obtain a result with your Moisture Analyzer that corresponds most closely to the reference value for the chosen temperature and sample quantity.

For **AutoMet** test measurement enter the reference value or reference value by pressing the «Target» key. As soon as this value is reached, the instrument automatically determines the optimum switch-off criterion for the chosen conditions. This is a free switch-off criterion F (Section 5.5), which after the measurement can be stored with the method by pressing the «Accept entry» key.

Once you have defined the target value you can enter the maximum length you require for the **AutoMet** test measurement. The range for the switch-off criterion F that can be determined with **AutoMet** is restricted to (1 mg/20 sec to 1 mg/180 sec).

AutoMet test measurement procedure

Press "Y" («Switch-off criterion» function key) to perform the **AutoMet** test measurement. Then press «Target» to define the reference value.

TARGET: 16.80 Enter the reference value in %

You can enter the reference value in %MC, %DC, %AM or %AD (depending on the setting). Confirm the reference value by pressing the «Target» or «Accept entry» key. Then you can set the maximum measuring time.

MAX.TIME: 30 Maximum time: 10 to 480 min

Confirm the maximum measuring time by pressing the «Target» or «Accept entry» key and the **AutoMet** test measurement will start.

Printing out the AutoMet test measurement

The parameters for the active method are printed out in the record header. The maximum time (e.g. 30 min) is also shown. The results for switch-off criteria 1 to 5 and F (if defined in the Methods menu) are printed. The value for **F** (1 mg / x sec) determined by **AutoMet** appears at the end of the record. If the test measurement was stopped before the specified time, the line MANUAL appears before the date.

Note: Depending on the settings in the Methods menu (Section 5.4), the data printout can contain other information, which is described in the relevant sections (Section 5.4.1 - 5.4.6).

There are three different scenarios for the **AutoMet** results:



Scenario 1: Switch-off criterion F within the range 1 mg / 20 – 180 seconds

As soon as the target value is reached, a “target” appears and is displayed until the test measurement is completed.

```

*****
AutoMet:
Target reached
Time           8:22 min
Switchoff mode F
              1 mg / 75 sec
*****
    
```

The **AutoMet** test measurement only suggests a switch-off criterion F if an accurate moisture determination can be expected as a result of the drying process. The range for the switch-off criterion F that can be determined with **AutoMet** is therefore restricted to the range 1 mg / 20 seconds to 1 mg / 180 seconds. **AutoMet** simplifies method determination in particular for samples whose drying curve tapers off slowly. This behavior is typical of organic samples and is illustrated by the fine flour example shown in Figure A (at the end of this section).

```

*****
AutoMet:
Target reached
Time           6:17 min
Switchoff mode F
              1 mg / >20 sec
Recommendation:
Switchoff mode 3
              1 mg / 50 sec
*****
    
```

For samples whose drying curve changes very little once switch-off criterion 2 has been reached (1 mg / 20 seconds), we recommend using switch-off criterion 3. This scenario is illustrated in Figure B (at the end of this section). The printout shows the measuring time until the target value is reached and “1 mg / > 20 sec” for switch-off criterion F. You can obtain the results for the fixed switch-off criteria 1 to 5 from the printed test record.

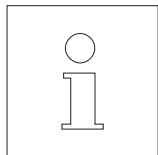

Since drying profiles can vary slightly even when the same method parameters are used (e.g. depending on the sample distribution), we recommend repeating the **AutoMet** test measurement (e.g. 3 sample throughputs) when developing a method. The mean value can then be stored as the method-specific switch-off criterion F (Section 5.4.1). This procedure allows the result from the Moisture Analyzer to be matched to the reference value as closely as possible.

Note: When performing the **AutoMet** test measurement, depending on the curve profile, there may be slight differences between the actual switch-off criterion F and the preset switch-off criterion. We therefore recommend carrying out a follow-up measurement to confirm the suitability of the switch-off criterion F determined with **AutoMet**.



Blank target

Scenario 2: Switch-off criterion F outside the range 1 mg / 20 – 180 seconds

If the target value is reached but a switch-off criterion cannot be determined within the permitted range, a “blank target” symbol is displayed.

The target value was reached, but the method parameters were not chosen correctly. The reproducibility of a moisture determination with switch-off criteria of “1 mg / < 20 seconds” is low. If this message appears and the actual moisture content was entered as the target value, the solution is normally to lower the drying temperature.

```
*****
AutoMet:
Target reached
Time          3:11 min
Switchoff mode F
              1 mg / <20 sec
*****
```

The target value was reached, but the switch-off criterion that was determined is 1 mg / > 180 seconds and is therefore outside the permitted range. If this message appears, in most cases the target value is almost reached with switch-off criterion 5 (1 mg / 140 seconds). If the actual moisture content was entered as the target value, raising the drying temperature may reduce the measuring time in this case.

```
*****
AutoMet:
Target reached
Time          17:33 min
Switchoff mode F
              1 mg / >180 sec
*****
```

Scenario 3: Target value not reached

If the target value was not reached in the predefined time, no target is displayed. If the actual moisture content was entered as the target value, increasing the measuring time (“MAX.TIME”) or changing the method parameters (e.g. raising the drying temperature or using a different drying program) may help.

```
*****
AutoMet:
Target not reached
Please change parameters
*****
```

Saving switch-off criterion F

On completion of the **AutoMet** test measurement, the **switch-off criterion F** that was obtained can be saved as a method parameter (Methods menu, see Section 5.4), although it has to be confirmed. If a suitable switch-off criterion was determined with **AutoMet**, at the end of the test measurement the line “F.SAVE: YES” is displayed. Press the «Accept entry» key to save the switch-off criterion F.



If you choose “NO” or press the «Reset» key, you can quit the **AutoMet** test function without saving the switch-off criterion F.



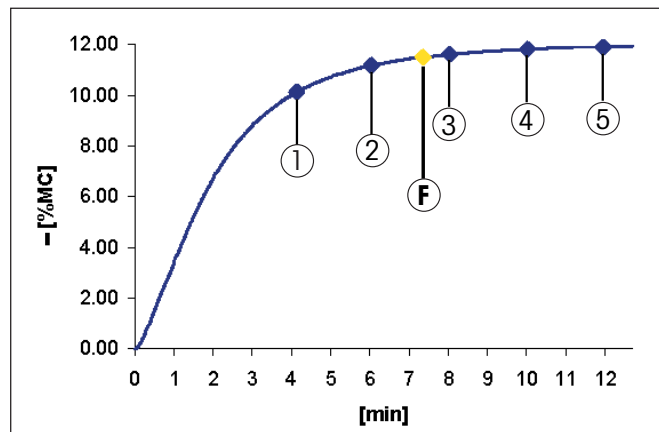

Figure A

Drying profile for a test measurement with 2.5 g fine flour (standard drying, 100 °C). The fixed switch-off criteria 1 to 5 are shown, along with the switch-off criterion F (1 mg / 35 seconds) determined with **AutoMet**, with which the exact target value (11.48 %) is reached.

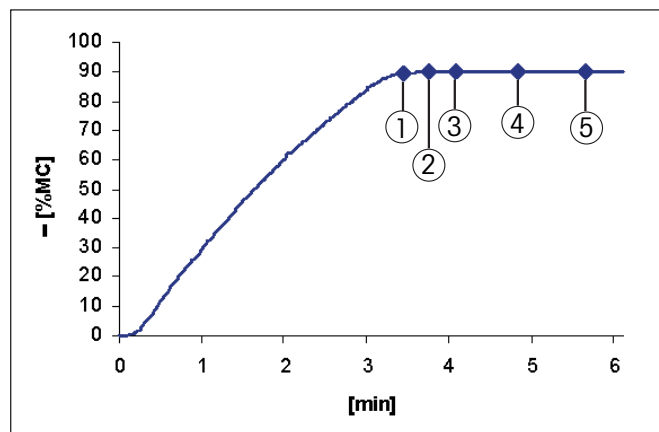

Figure B

Drying profile for a test measurement with 2.5 g 90% (w/w) potassium chloride solution (standard drying, 160 °C). The fixed switch-off criteria 1 to 5 are shown. Once switch-off criterion 2 is reached, the result changes only slightly. In order to reach the target value (90%) **AutoMet** proposes switch-off criterion 3.



AutoMet test measurement is a quick way of determining your method parameters. However, you must always personally check the suitability of switch-off criteria and other method parameters for the intended purpose (e.g. by analyzing samples with different moisture contents).

Note: Test measurements are not entered in the journal or the statistics (Sections 5.11 and 5.12).

5 Methods facilitate your work

Methods simplify and accelerate your daily work. In this Section you will learn how you compile, print out and change methods and how to use them. You will also become acquainted with the journal function and the statistics. You will find an overview diagram of all menu options in Section 5.4.

5.1 What is a method?

Perhaps you remember: In Section 4 you became acquainted with all the parameters and setting possibilities you can use to match your Moisture Analyzer to a particular measurement task. If you have to change samples frequently during your work, the methods save you having to reenter the parameters and preclude wrong settings. Methods thus make it easier for you to switch between different types of samples.

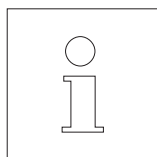
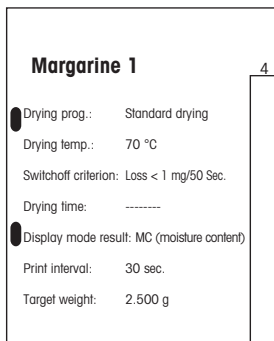
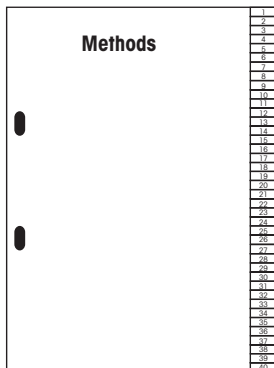
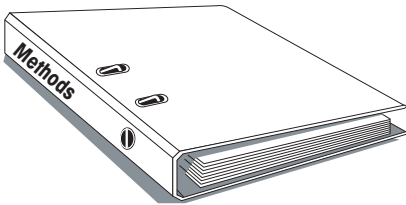

A method contains all **settings** for a particular sample. It can be recalled at a keystroke and your instrument immediately operates with the corresponding settings. You have 40 methods freely available.

The following parameters, which you have already learned in section 4, form part of a method:

- Drying program
- Drying temperature
- Switch-off criterion
- Drying time (depends on switch-off criterion)
- Display mode
- Print interval
- Target weight for weighing-in aid
- Settings in the Method menu (Section 5.4)

Each method has its own measured value journal and its own measured value statistics.

You will find information on the journal and statistics in Sections 5.6 and 5.7.

Work with methods is divided into two stages: in the **setting stage** you define the parameters of the method and name the method. In the **utilization stage** you perform routine measurements with different samples. When switching from one sample to the next, you do not have to change any settings, you need simply select the method suitable for the sample. You will find information on how to use and set up of methods in the following Sections.

5.2 Recalling a method

To activate all settings for a particular sample, simply call up the associated method. After recall of the method, all appropriate settings become immediately active.

To recall an existing method (consult the next section for information on how to compile methods), proceed as follows:



Press the «Method» key. The fixed method numbers (01-40) flash on the screen and the name of the active method is displayed.



Now use the «Scroll up» and «Scroll down» keys to select the method. Then press the «Accept entry» key. You can also enter the method number directly via the numeric keypad.

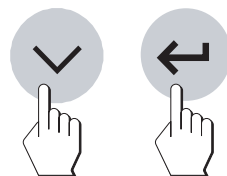

All settings of the selected method are now active and you can immediately perform your measurement.

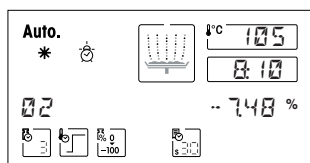

During the measurement the number of the active method (e.g. method number 02) is displayed. The method number and method name are printed on the measurement record.

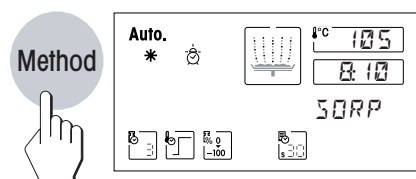

If you press the «Method» key during the measurement, the name of the active method is displayed. If the name contains more than 10 characters, you can view the rest of the name by pressing the «Method» key again.

5.3 Naming, compiling or changing methods

When you put your Moisture Analyzer into operation for the first time, all 40 methods are identical and are allotted the factory setting for all parameters. You can change the parameters of a method at any time (except when a measurement is running or the settings are protected against change as described in Section 6.13).

The compilation of a new or the modification of an existing method comprises 3 steps:

- Selecting a method (01 - 40)
- Naming a method (optional)
- Selection of the settings



Selecting a method

Press the «Method» key.

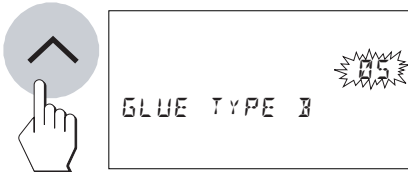

Now use the «Scroll up» and «Scroll down» keys to select the method you wish to name, recompile or change. The illustrations show the method for naming and compiling a new method which should be assigned the name "Glue type B".



Alternatively you can use the keys on the numeric keypad to select a method.

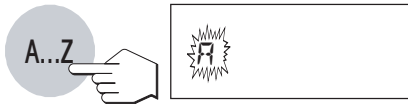

Naming a method

To name a method press the «A...Z» key. A flashing "A" appears at the first input position on the extreme left and signals that the instrument is ready for your entry. The procedure for changing an existing method name, without needing to enter the new name completely, is described later.

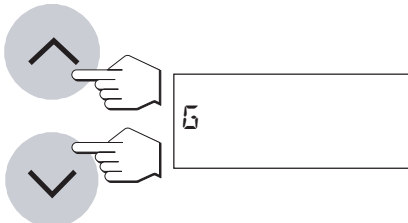

You can now use the «Scroll up» and «Scroll down» keys to select the first letter of the designation (uppercase letters only) or a special character (+, -, etc.).

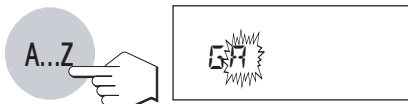

Confirm your entry with the «A...Z» key. The flashing "A" reappears, but at the second position. Enter the additional characters of the desired method name as described above.

Notes

- A space is symbolized by the underline character "_".
- You can remove wrong characters or numbers with the «Delete» key and then correct your entry.
- Numbers can be entered directly via the numeric keypad. If you enter a character via the numeric keypad, the instrument remains in numeric input mode and a flashing dash appears at the next input position instead of a flashing "A". To switch back to the text mode, press the «A...Z» key again.

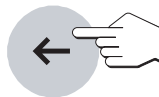

If you want to change an existing method name (e.g. entering a serial number), proceed as follows:



Press the «Method» key. The designation of the currently active method flashes in the display.

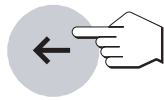

Press the «Delete» key (to activate edit mode). A flashing underline character is displayed after the last number or the last character flashes, indicating that the system is ready for input.



You can then add additional characters by pressing the «A...Z» key or a number key on the numeric keypad.

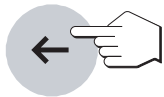

By pressing the «Delete» key a second time you can delete the last character. The second last character flashes and can be changed using the numeric keypad or the «Scroll up» and «Scroll down» keys, or confirmed with the «A...Z» key. Further characters can then be added as described above.

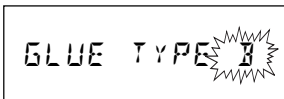

As soon as you have finished entering the designation, press the «Accept entry» key to quit the input mode (the flashing character is also accepted).

Selecting the settings

The selected method is now ready for the entry or change of the parameters.

Now use the appropriate keys to match the following parameters to your measurement task:

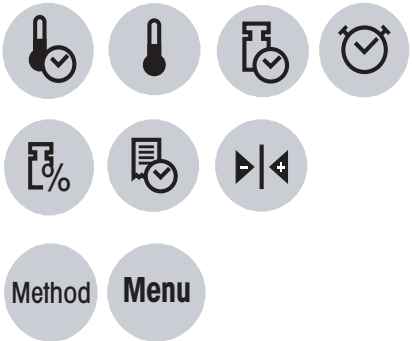

- Drying program
- Drying temperature
- Switch-off criterion
- Drying time (dependent on switch-off criterion)
- Display mode
- Print interval
- Target weight for weighing-in aid
- Settings in the Methods menu (Section 5.4)

Please consult Section 4 for the meaning of the individual parameters and details on how to proceed.

All settings are assigned to the selected method and automatically stored.

After you have completed all settings, your instrument is ready for measurement with the new or changed method.

Notes

- The methods can be protected in the menu against changes (see Section 6.13).
- We advise you to define a special method for test purposes, e.g. with the name "Test". You can always change the settings of this method to test the individual parameters without altering the methods you have already defined.

5.4 Method menu

If you press the «Method» key followed by the «Menu» key, the Method menu opens (you will find additional information on using the menu in Section 6).

You can define the following settings here: Free switch-off criterion, Free factor -MC, Free factor **F.F.G**, Method compilation, High resolution (with standby temperature) and drying temperature up to 200 °C without time limitation.

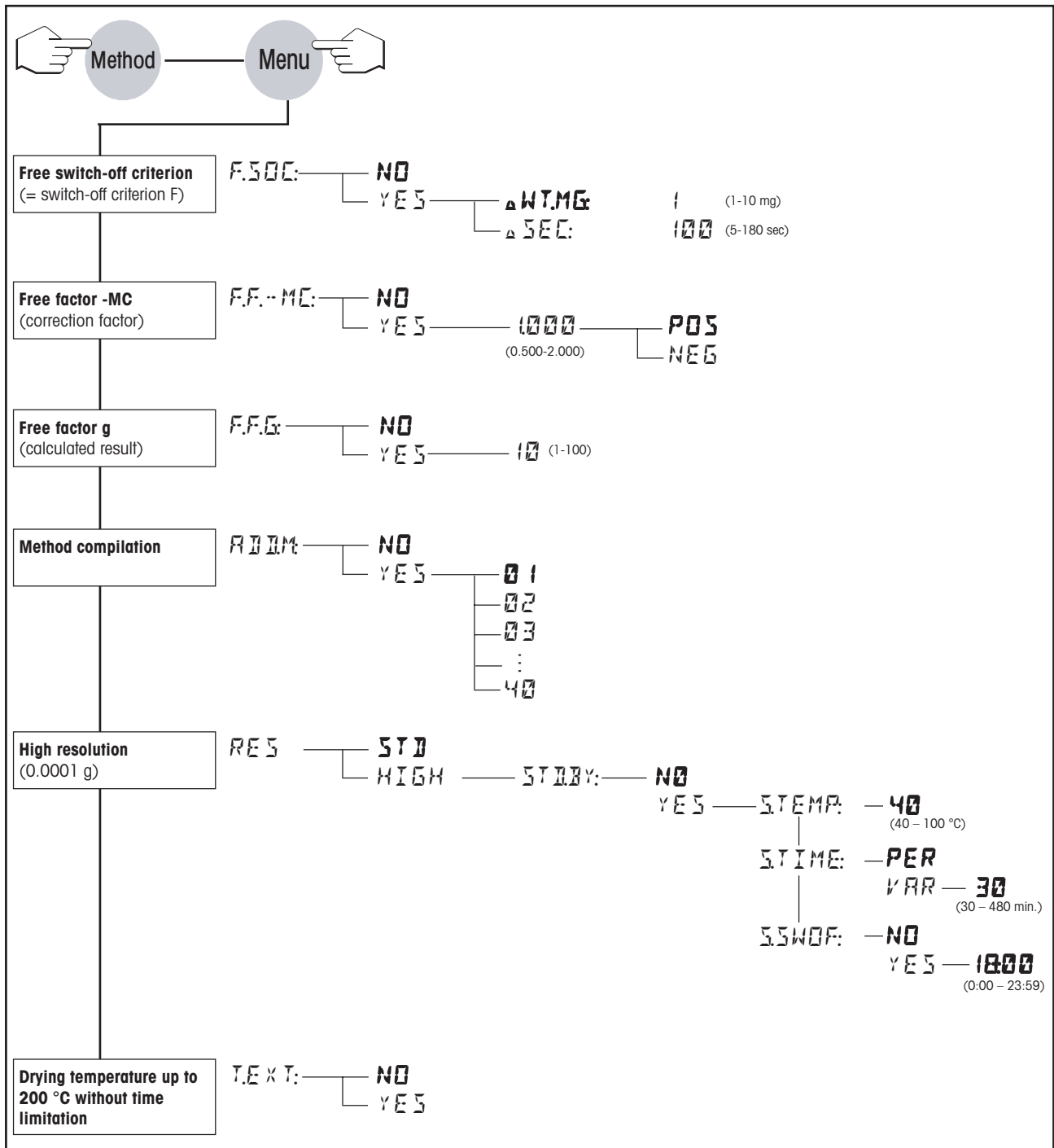

5.4.1 Freely selectable switch-off criterion

The free switch-off criterion (= switch-off criterion F) is based on the principle of the mean weight loss per unit of time. As soon as this drops below the preset value, the measurement is automatically ended. Alternatively the free switch-off criterion can be determined automatically with the **AutoMet** function and stored with the method, see Section 4.12 **AutoMet** test measurement.



Press the «Method» key followed by the «Menu» key to open the Method menu.

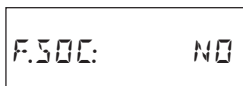

The free switch-off criterion is deactivated ("NO") as the factory setting.

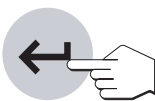
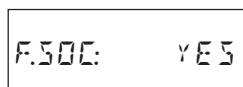

If you wish to set a free switch-off criterion, use the «Scroll up» and «Scroll down» keys to select "YES" and then press «Accept entry» to confirm.

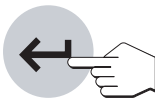
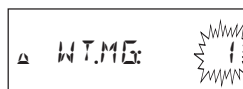

A flashing 1 will appear in the display. Then use the «Scroll up» and «Scroll down» keys or the numeric keypad to enter the weight loss (1 mg to 10 mg) in 1 mg increments. Press the «Accept entry» key to confirm your input.

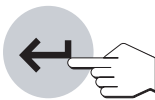
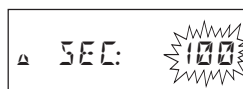

Now enter the time in the flashing field. You can alter it in 5-second increments using the «Scroll up» and «Scroll down» keys or enter any value between 5 and 180 via the numeric keypad. Press the «Accept entry» key to confirm your input.

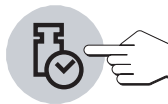

Note: To perform a measurement with a free switch-off criterion, it must be defined in the Method menu. "F" must also be selected as the switch-off criterion (see Section 4.4).

5.4.2 Free factor (-MC)

The free factor **F.F.-MC** (0.500 to 2.000) for the moisture content can be defined in the Method menu. It is used to calculate a corrected final result (e.g. in order to compensate for systematic deviations from the reference result).

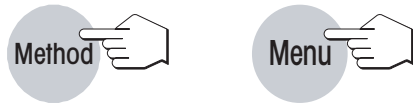

Press the «Method» key followed by the «Menu» key to open the Method menu.

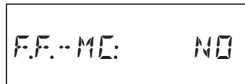

The free factor (-MC) is deactivated ("NO") as the factory setting.



If you wish to set the free factor **F.F.-MC**, use the «Scroll up» and «Scroll down» keys to select "YES" and then press «Accept entry» to confirm.



Now enter the factor in the flashing field. You can alter it using the «Scroll up» and «Scroll down» keys or enter any value between 0.500 and 2.000 via the numeric keypad. Press the «Accept entry» key to confirm your input.



You can specify whether the factor has a positive ("POS") or negative ("NEG") sign.

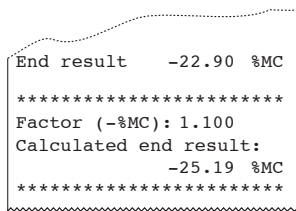

The final result is multiplied by the method-specific factor (0.500 to 2.000) in **%MC display mode** and highlighted on the printout as the calculated final result.

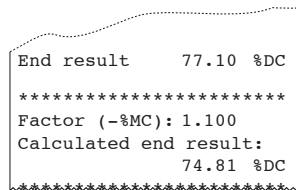

In **%DC display mode**, if you define a free factor (-MC), the final result %DC is converted by means of the formula below and highlighted on the printout.

$$\%DC = 100 + (\text{factor} \times \%MC)$$

Note: In **%AM**, **%AD** or **g** display mode, the final result is not converted.

5.4.3 Free factor (g)

The free factor **F.F.G** (1 to 100) can be defined regardless of the display mode setting - %MC, %DC, %AM, %AD or g.



Press the «Method» key followed by the «Menu» key to open the Method menu.



The free factor F.F.G is deactivated ("NO") as the factory setting.



If you wish to set the free factor **F.F.G**, use the «Scroll up» and «Scroll down» keys to select "YES" and then press «Accept entry» to confirm.



Now enter the factor in the flashing field. You can alter it using the «Scroll up» and «Scroll down» keys or enter any value between 1 and 100 via the numeric keypad. Press the «Accept entry» key to confirm your input.

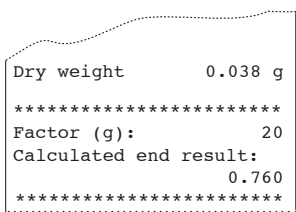

In %MC, %DC, %AM or %AD display mode, defining a **F.F.G** does not convert the final result.

5.4.4 Compiling methods

You can compile two methods, which means that the second measurement is performed automatically after the first one. The tare value from the first measurement is automatically used for the second. The dry weight from the first measurement serves as the starting weight for the second measurement.

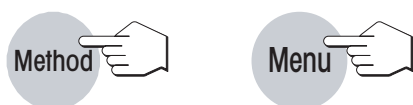

Press the «Method» key followed by the «Menu» key to open the Method menu.

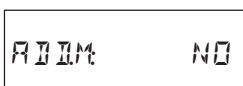

Method compilation is deactivated ("NO") as the factory setting.

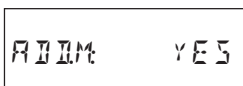

If you wish to enable method compilation **ADD.M:**, use the «Scroll up» and «Scroll down» keys to select "YES" and then press «Accept entry» to confirm.

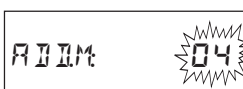

Now enter the method you wish to add in the flashing field (enter the number via the numeric keypad). Press the «Accept entry» key to confirm your input.

```
-----  
- MOISTURE DETERMINATION -  
-----  
METTLER TOLEDO  
Halogen MoistureAnalyzer  
Type: HR83  
SNR: 1234567890  
SW: 2.01  
  
Method:  
04 RESIN-50  
C1: CRUDE PRODUCT  
C2: CHARGE 125  
C3: SYSTEM B  
C4: H.MUSTER  
Switchoff mode 3  
Standard drying  
Drying temp. 50 °C  
Disp.mode 0...-100 %MC  
Start weight 2.543 g
```

```
Total time 2:44 min  
Dry weight 1.961 g  
End result -22.90 %MC  
  
----30.06.03---15:28----  
  
Method (AddMet):  
05 RESIN-120  
Switchoff mode F  
1 mg / 80 sec  
Gentle drying  
Drying temp. 120 °C  
Disp.mode 0...-100 %MC  
Start weight 1.961 g  
  
Total time 5:33 min  
Dry weight 0.821 g  
End result -41.87 %MC  
  
----30.06.03---15:33----
```

In the adjacent record you can see for example that method 04 (resin-50) has been added to method 05 (resin-120). **At the end of the measurement the first method (resin-50) is activated again.**

Note: Multiple compilations are not executed and a method cannot be compiled with itself.

5.4.5 High resolution

Traditionally, moisture analyzers are operated at a maximum resolution of 0.01%. The following setting allows you to determine moisture content using the resolution of the built-in analytical balance, which is ten times higher (0.1 mg weight / 0.001% moisture). The high resolution is especially suitable for samples with low moisture content that contain no other high-volatile substances besides water. Careful sample preparation is extremely important for these kinds of samples! **Note:** High resolution is not available for the display modes "ATRO moisture content" and "ATRO dry content" (Section 4.5).

Other optional settings become available after the high resolution is activated: You can activate the standby temperature and define its parameters (temperature, duration and switch-off time).



Press the «Method» key followed by the «Menu» key to open the Methods menu. You can access the "RES: STD" menu item by repeatedly pressing the "Menu" button.



The standard resolution is activated at the factory ("STD").

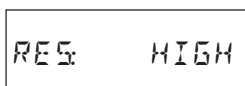

If you wish to activate the high resolution, use the «Scroll up» and «Scroll down» keys to select "HIGH" and then press «Accept entry» to confirm. The initial weight and the final weight, as well as the result, are printed with the high resolution. The final result with the high resolution is shown in the display (the standard resolution is used while measuring).

5.4.5.1 Standby temperature

If necessary, you can activate the standby temperature to preheat the instrument after activating the high resolution. Because of the short heat-up times with halogen moisture analyzers, no preheating is usually required for standard applications. Under unusually heavy use, a preheated instrument can sometimes improve the reproducibility of the results, since the instrument is in the same climatic state with every measurement. **Note:** For the highest accuracy, a preheating period of 15 minutes is recommended for the first measurement (a shorter preheating period is shown in the time window of the display and recorded on the printout, e.g. "Standby period 9 min.").

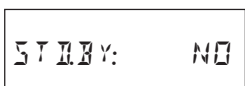

The standby temperature is deactivated ("NO") as the factory setting.

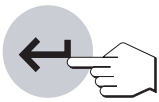
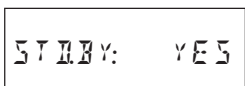

If you wish to activate the standby temperature, use the «Scroll up» and «Scroll down» keys to select "YES" and then press «Accept entry» to confirm.

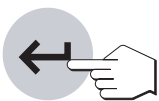

Now enter the **standby temperature** in the flashing field. You can use the «Scroll up» and «Scroll down» keys or the numeric keypad to select a temperature within the range of 40 °C (factory setting) to 100 °C. Press the «Accept entry» key to confirm your entry.

Note: High standby temperatures can result in possible moisture loss while weighing. You cannot select a standby temperature that is higher than the final drying temperature. Otherwise, the message "Error 10" appears (Section 8.2).

Setting the **standby time** allows you to define whether the instrument is maintained at standby temperature continually or only for a limited amount of time after measurement.

STIME: PER

STIME: VAR

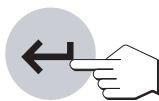

In the factory, the standby time is set so that the instrument is permanently maintained at the standby temperature ("PER").

If you wish to limit the standby time, use the «Scroll up» and «Scroll down» keys to select "VAR" and then press «Accept entry» to confirm.

STIME: 30

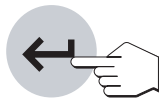

Now enter the desired standby time in the flashing field. You can use the «Scroll up» and «Scroll down» keys or the numeric keypad to select the standby time within the range of 30 minutes (factory setting) to 480 minutes. Press the «Accept entry» key to confirm your entry.

You can now select whether you want to define a **standby switch-off time**. This defines what time standby operation is cancelled. When this time is reached, the instrument is no longer maintained at the standby temperature. This prevents the instrument from continuing to heat after the working day is over, for example.

SSWOF: NO

SSWOF: YES

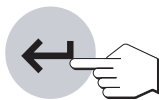

In the factory, the standby switch-off time is deactivated ("NO"), i.e. the instrument is permanently maintained at the standby temperature.

If you wish to activate the standby switch-off time, use the «Scroll up» and «Scroll down» keys to select "YES" and then press «Accept entry» to confirm.

SSWOF: 18:00



Now enter the standby switch-off time in the flashing field. You can use the «Scroll up» and «Scroll down» keys or the numeric keypad to select a time within the range of 0:00 - 23:59 (factory setting is 18:00). Press the «Accept entry» key to confirm your entry.

Note

- The switch-off time is based on the moisture analyzer's internal clock, and we recommend that you check its setting.
- If you define both a standby time and a standby switch-off time, the standby operation is switched off based on whichever condition is fulfilled first.

- You can cancel standby operation at any time by switching off the instrument. The next time the instrument is switched on, it continues working with the standby settings of the most recently active method.
- The status display opposite shows that the device is heating with the standby temperature.

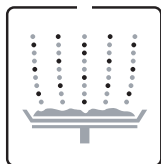

5.4.5.2 Recording the settings

```
Method:
01
Standbytemp.    50 °C
Time           60 min
Switch-off     18:00
```

```
Disp. mode      %MC
>>Standby period 11 min
Start weight    4.9989 g

0:30 min       -0.44 %MC
1:00 min       -0.45 %MC

Total time      1:35 min
Dry weight      4.9743 g
Moisture        0.0246 g

End result      -0.492 %MC
```

```
-----
-- METHODS-PARAMETERS --
METTLER-TOLEDO
Halogen MoistureAnalyzer
Type:           HR83
SNR:            1113000000
SW:             2.10

Method:
01
Standbytemp.    50 °C
Time           60 min
Switch-off     18:00
Switchoff mode  1
Standard drying
Drying temp.    105 °C
Disp.mode       g
Print interval  0:30 min
-----
```

The settings selected in the methods menu for “High resolution” are documented in the printouts. The figure at left shows a section from the data printout of a moisture measurement; the figure at right shows a printout of the methods setting (see also Section 5.5). The specific information for “High resolution” is shown in bold.

5.4.6 Drying temperature to 200 °C without time limitation

In the standard setting of your moisture analyzer, drying temperatures of 160 °C to 200 °C are possible for only a limited period of time. After the temperature reaches this range, the instrument lowers the temperature back to 160 °C (this function is described in Section 4.3). For the sake of backward compatibility with previously developed methods, this time limitation continues to be the standard setting of the instrument.

However, if needed, the **temperature extension** setting is available to you in the Methods menu, and allows drying temperatures of up to 200 °C **without time limitation**.

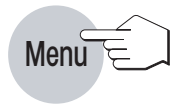

Press the «Method» key followed by the «Menu» key to open the Methods menu.

```
T.E X T:   NO
```

Temperature extension is deactivated ("NO") as the factory setting.

```
T.E X T:   YES
```

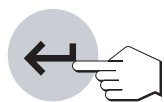

If you wish to activate the temperature extension, use the «Scroll up» and «Scroll down» keys to select "YES" and then press «Accept entry» to confirm.

Note

- When working with temperatures over 180 °C, we recommend that you always wait 2 to 3 minutes between individual measurements, in order to ensure good reproducibility of the readings.
- A measurement cannot be started until the drying temperature is higher than the temperature in the measuring room. Otherwise, the message "Error 10" appears (Section 8.2).
- In the data printouts the temperature extension is documented as shown at left.

```
Switchoff mode    1
Standard drying
Drying temp.     185 °C
No temp. lowering
Disp.mode        g
Print interval   0:30 min
```

5.5 Printing out methods

To ensure you do not lose your overview of the 40 methods, you can:

- print out a list of all methods or
- record the parameters of a particular method.

Note: Please note that these print functions are available only in the standby mode of the instrument and not during a measurement.

How to print out a list of all methods



Press the «Method» key.



```

----- METHOD-LIST -----
METTLER TOLEDO
Halogen MoistureAnalyzer
Type:          HR83
SNR:          1234567890
SW:           2.01

01             MARGARINE
02  MARGARINE-LIGHT-105
03             KETCHUP
04
05             ORANGE JUICE
06

40

-----30.06.03---15:48-----
    
```

Press the «Print» key. The list with the designations of all methods will be printed out.



After the list has been printed out, press the «Reset» key to return the instrument to the standby mode.

How to print out the settings of a particular method:



Call up the desired method (if not already active):
Press the «Method» key and select the method with the «Scroll up» and «Scroll down» keys.

```

MARGARINE
    
```



Confirm your selection with the «Accept entry» key.



```

----- METHODS-PARAMETERS -----
PHARMA LTD
CENTRAL LABORATORY

METTLER TOLEDO
Halogen MoistureAnalyzer
Type:          HR83
SNR:          1234567890
SW:           2.01

Method:
34             SODIUM TARTRATE
C1:            CHECK
Switchoff mode 3
Gentle drying
Drying temp.   150 °C
Disp.mode      0...-100 %MC
Print interval 1:00 min
Target weight  2.500 g
Active         +/-10 %

-----30.06.03---15:50-----
    
```

Press the «Print» key. A list of all parameters for the selected method is printed. Please consult Section 4 for the meaning of the individual parameters and settings. Depending on the settings, your record may look slightly different.

5.6 Measured value journal

The journal function always provides you with an overview of the last 20 final results of each method.

MARGARINE



Select the method whose measured value journal you wish to view.

Confirm your selection with the «Accept entry» key.

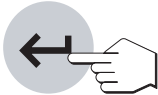

Press the «Journal» key and ...

* 1140
42 -- 23.59 %
% 0
-100

... the display shows the data of the measurement last performed. The following data are shown for every measurement:

- the time of the measurement
- the consecutive number of the measurement (serial number)
- the final result (the asterisk symbol in the top left corner of the display signals that the result has been calculated)
- the selected display unit, which can be changed. If “grams” have been selected as the display unit, the dry weight is displayed.

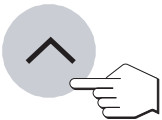

You can use the «Scroll up» and «Scroll down» keys to view the data of the other recorded measurements in turn.



Note: With the «Reset» key you can terminate the display of the measured value journal at any time (the measured values will not be deleted).



```

----- JOURNAL -----
METTLER TOLEDO
Halogen MoistureAnalyzer
Type:                HR83
SNR:                 1234567890
SW:                  2.01

Method:
37                   MARGARINE

10.08.02 / 12:46
224                  99.28 %DC
10.08.02 / 13:03
225                  99.28 %DC

30.06.03 / 13:38
243                  67.54 %DC
-----30.06.03---15:56-----
  
```

If your instrument is equipped with a built-in printer, you can print out the entire journal on the printer with the «Print» key. In addition to the data in the display, the date of every measurement will be printed out.



After pressing the «Accept entry» key you are asked if you wish to clear the measured value journal.

The suggested answer is "NO". If you do not wish to clear the measured value journal, press the «Accept entry» key now to confirm your selection and quit the journal display. The journal will continue to be kept with the measured values already recorded..

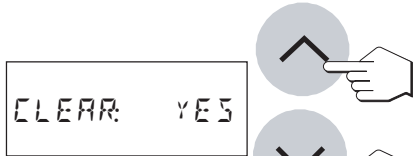

If you wish to clear the journal, use the «Scroll up» or «Scroll down» key to select the response "YES".



Then press the «Accept entry» key to confirm your selection. The existing journal will be cleared and a new journal created.

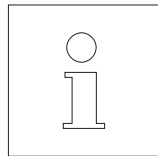
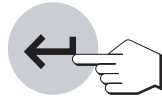

Note: If you do not want measured data to be recorded in the instrument, you can switch off the journal function in the menu (see Section 6.19).

5.7 Measured value statistics

Your Moisture Analyzer keeps measured value statistics for each of the 40 methods. The measurement results of each method are continuously recorded and transferred to the statistics. The statistics are updated until they are cleared. After clearance, a new set of measured value statistics is created.



Select the method whose measured value statistics you wish to view.

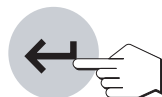

Confirm your selection with the «Accept entry» key.



Press the «Stat.» key and ...



... the display shows the first value of the statistics (the number of measurement results).



You can use the «Scroll up» and «Scroll down» keys to view the additional data of the measured value statistics in turn.

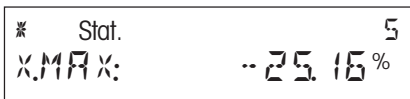
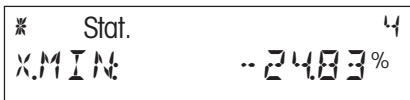
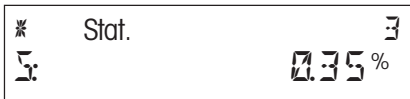
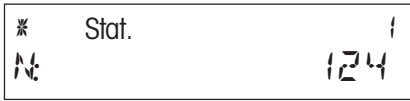

The individual values have the following meaning:

– **Number of measurement results** recorded in the statistics (maximum 9999). The run number on the full records (see Section 6.17) corresponds to the number of measurement results (sample size).

– **Mean value of all measurements** in the selected display unit:

$$\bar{x} = \frac{1}{n} \sum_{i=1}^n x_i$$

– **Standard deviation** in the selected display unit:

$$s = \sqrt{\frac{1}{n-1} \sum (x_i - \bar{x})^2}$$

– **Lowest recorded measurement result.**

– **Highest recorded measurement result.**

– **Absolute difference** between highest and lowest result.



Note: You can press the «Reset» key to terminate the display of the measured value statistics at any time (the measured values will not be deleted).

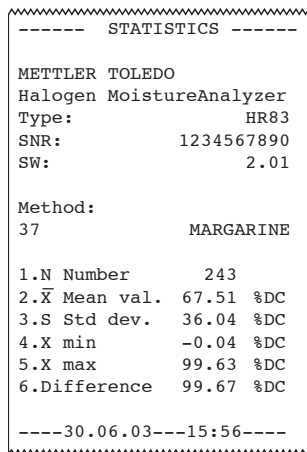

If your instrument is equipped with a built-in printer, you can print out all statistical data of the current method on the printer with the «Print» key.

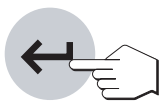

After pressing the «Accept entry» key, you are asked if you wish to clear the measured value statistics.

The «Scroll up» or «Scroll down» key offers the following possibilities:

- "NO": The measured value statistics will not be cleared, but continued with the measured values already recorded.
- "Value": The measured value last recorded in the statistics will be deleted and the statistics will be continued with the remaining values. This allows you to delete wrong measurements. The deletion must be performed before the next value is recorded as only the last value is deleted!
- "YES": All the existing measured value statistics will be completely cleared and a new set of statistics created.

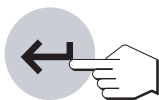

Select the desired option and then press the «Accept entry» key to confirm your selection and quit the statistics display.

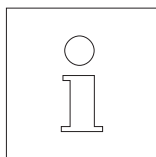

Note: If you do not want measured data to be recorded in the instrument, you can switch off the statistics function in the menu (see Section 6.19).

6 The menu (basic settings of the instrument)

In this Section you will learn how to use the menu to define the settings your instrument uses for operation. You will also find out how to adjust the integral balance and the heating module. The menu is a list of selection possibilities which you can use to preselect the **basic setting** of your instrument. The menu comprises various options (you will find an overview diagram of all menu options in Section 6.24). In addition to the settings (which are numbered for clarity), certain **functions** (e.g. balance adjustment and heating module adjustment) can also be performed. All menu settings are retained even in the event of a power failure.

Using the menu is simple:



Press the «Menu» key to call up the menu. The first menu option is password definition (Section 6.1). All other menu items can be accessed by pressing the «Menu» or «Accept entry» key repeatedly.

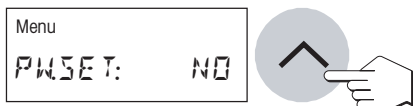

You can use the «Scroll up» and «Scroll down» keys to switch between the selection possibilities within the current menu items and hence select the desired setting or execute the particular function.

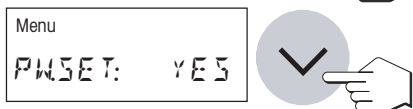

Save changes

Once you have defined your setting in a menu option, press the «Accept entry» key. The setting will be saved and the next menu option opened.

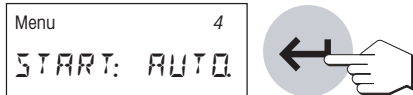

Do not save changes

If you close a menu option by pressing the «Reset» key, the changes made in the current menu option will not be saved.



Print menu settings

If your instrument is equipped with a built-in printer, you can record all menu settings. To do this simply press the «Menu» key followed by the «Print» key.

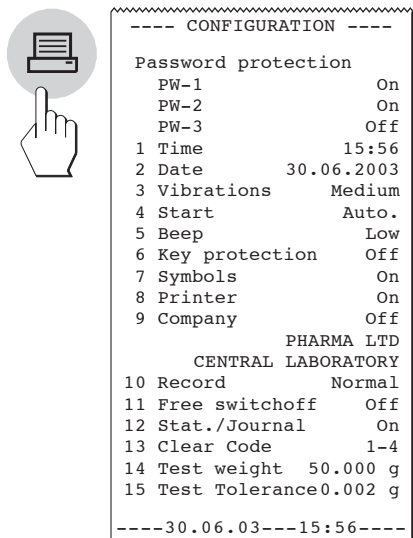

The following Sections will acquaint you with the individual menu items. The order corresponds exactly to that in the menu.

6.1 Password protection

In this menu option you can protect your instrument against accidental changes to the **menu** and **method settings** and **method changes** with a 3-level password (for details of how to protect the method settings without a password, see Section 6.13).

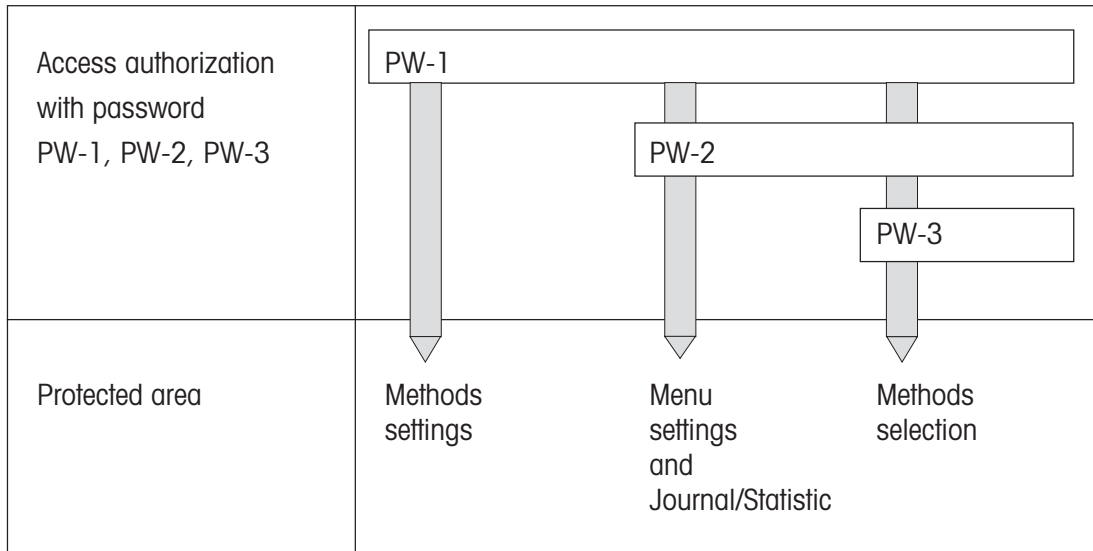

Note: Password protection is limited to keyboard inputs (there is no protection via the LocalCAN universal interface).

Set password

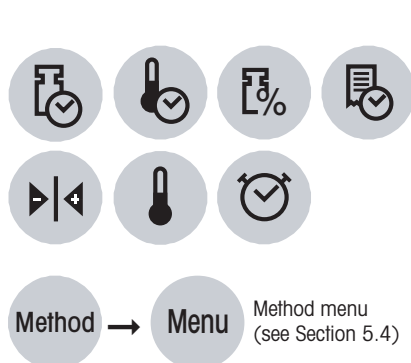
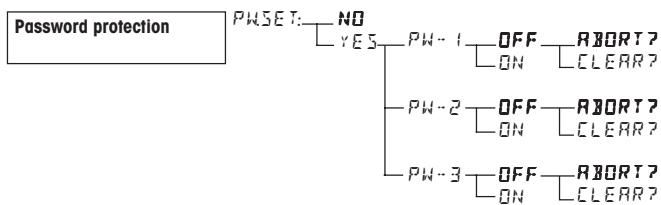

Password PW-1

PW-1 protects all method settings, including the Method menu (see Section 5.4). In addition, the method memory can only be cleared and the factory settings restored if PW-1 is not set. Also, if PW-1 is set (PW-1: ON), menu option 6 (protecting method settings without a password) is not available (Error 12, see Section 8.2). **Method settings can only be defined if PW-1 is set to OFF.** PW-1 can be reset by entering PW-1 (**PW-1: OFF**).

Note: The administrator (PW-1) requires only one password and can also use his/her password (level 1) to reset and redefine PW-2 and PW-3.

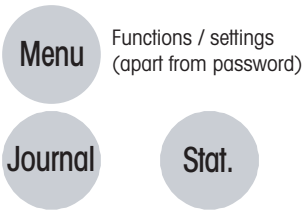

Password PW-2

PW-2 protects all non-method-specific menu functions and menu settings, along with the statistics and journal function, against unauthorized access. **You are prompts for PW-2 (E.PW2:) on opening the menu and also if you press the Stat. or Journal keys.** PW-2 can be reset by correctly entering PW-1 or PW-2.

Note: To input for PW-2, both PW-1 and PW-2 are accepted.

Password PW-3

PW-3 ensures that only authorized persons can select methods. **You are prompts to enter PW-3 (E.PW3:) when you press the «Method» key.** PW-3 can be reset by correctly entering PW-1, PW-2 or PW-3.

Note: To input for for PW-3, PW-1, PW-2 and PW-3 are all accepted.

Set password (Example: PW-1)

The factory setting for this menu option is "NO" (no password protection).

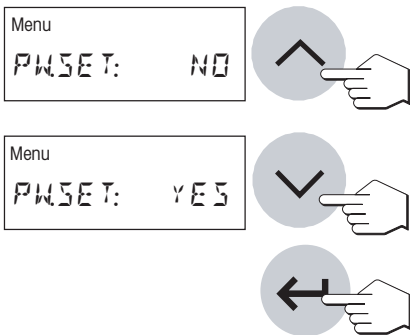

To work with a password (PW), press the «Menu» key and use the «Scroll up» and «Scroll down» keys to select "YES". Press the «Accept entry» key to confirm your input.

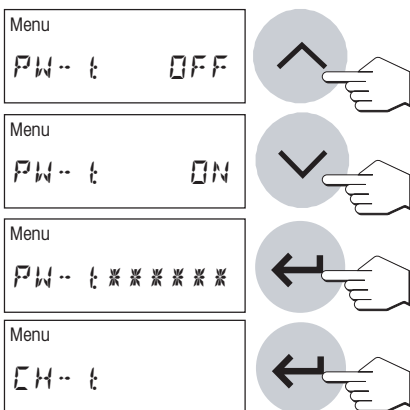

In PW-1 select "ON", press «Accept entry» to confirm this and enter a numerical password (max. 6 digits, displayed as asterisks). Press the «Accept entry» key to confirm your input.

Once you have set the password you must enter it again (CH-1). Press the «Accept entry» key to confirm your input.

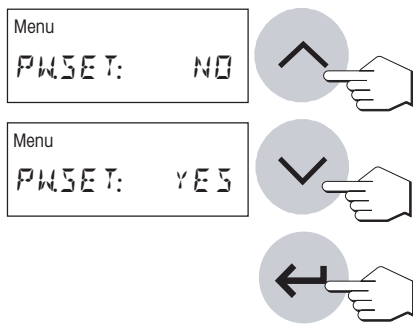

Deactivate password (Example: PW-1)

To deactivate or change the password (PW) as shown in this example, press the «Menu» key and use the «Scroll up» and «Scroll down» keys to select "YES". Press the «Accept entry» key to confirm your input.

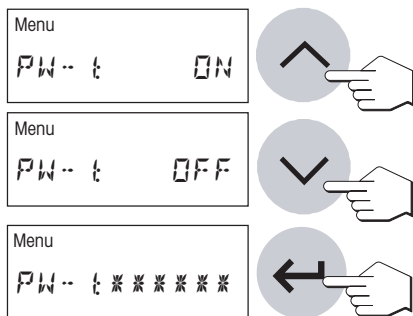

Use the «Scroll up» and «Scroll down» keys to select "OFF". Press the «Accept entry» key to confirm your input. Enter the password and press «Accept entry».

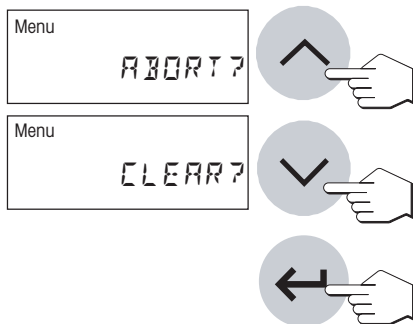

When you press the «Accept entry» key, the prompt "ABORT?" or "CLEAR?" appears. Choose "CLEAR" and press «Accept entry» to confirm. Press the «Reset» key to leave the menu.

6.2 Adjusting the balance

In this menu item you can adjust the balance of your instrument. Consult Section 3.2 to learn when an adjustment is necessary. Before selecting the adjustment function, ensure that the sample pan is in position. Following a drying, you should wait at least 30 minutes before undertaking an adjustment.



The factory setting in this menu item is "NO" (no balance adjustment).

Note: The number above the word "NO" shows the number of adjustments performed to date.



If you wish to adjust the integral balance, select "YES" (using the «Scroll up» or «Scroll down» key).



Press the «Accept entry» key to start the adjustment process. The sample chamber automatically opens.



The flashing display then prompts you to enter the adjustment weight (50 g).

Note: Ensure that your instrument is in a suitable location (see Section 2.2).

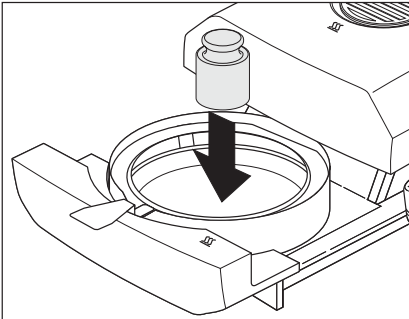

Place the requested adjustment weight in the middle of the sample pan. The weight is automatically recorded.

Note: The 50 g adjustment weight is available as optional equipment (see Section 9.9).



The instrument stores the determined weight value and the display prompts you to lift off the adjustment weight.

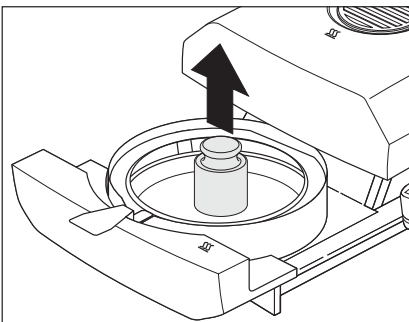

Remove the adjustment weight.

This concludes the adjustment of the balance and the instrument automatically quits the menu and returns to the standby mode. The Moisture Analyzer is now ready for further measurements.

```

A  -- BALANCE ADJUSTMENT --
B  30.06.2003      14:48

C  METTLER TOLEDO
   Halogen MoistureAnalyzer
D  Type:          HR83
E  SNR:          1234567890
F  SW:           2.01
G  Balance Adjustment  159

H  Weight ID:

.....
I  Weight:       50.000 g

J  Adjustment performed
   Signature:

.....
----- END -----
    
```

If your instrument is equipped with the built-in printer and this is activated (see Section 6.15), on completion of the balance adjustment an adjustment record will be automatically printed out with the following data:

- A** Record title
- B** Date and Time of the record printout of the balance adjustment
- C** Manufacturer and Designation of the instrument
- D** Type of the instrument
- E** Serial number of the instrument
- F** Version number of the software
- G** Identification (consecutive number) of the balance adjustment, allows assignment of the measurement record to the appropriate adjustment record
- H** Field for entry of the number of the adjustment weight used
- I** Adjustment weight used
- J** Field for signature of the person who performed the balance adjustment

Please enter the number of the adjustment weight used, sign the record and store it in a safe place. This assures traceability, one of the basic requirements of every quality assurance system.

In the "W.CAL" menu you can print out the latest adjustment record at any time by pressing the «Print» key. Only one original copy (with signature field) can be printed, however.



6.3 Testing the balance

In this menu option you can test the balance on your instrument.

```

Menu
W.CAL:          NO
    
```

Checking balance adjustment

The factory setting in this menu item is "NO" (no balance adjustment).

```

Menu
W.CAL:          TEST
    
```

To test (calibrate) the integral balance, use the «Scroll up» or «Scroll down» keys to select "TEST". The test weight to be used can be defined in the menu (see Section 6.21).

Note: Ensure that your instrument is in a suitable location (see Section 2.2).

Press the «Accept entry» key to start the test procedure. The sample chamber opens automatically.

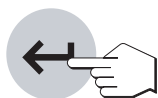

```

Menu
W.CAL:          50000g
    
```

The flashing display then prompts you for the defined test weight.

Place the test weight on the balance. The rest of the procedure then continues automatically.

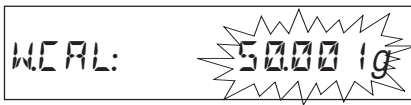

The display then shows you the recorded weight.
The test record is printed out automatically.

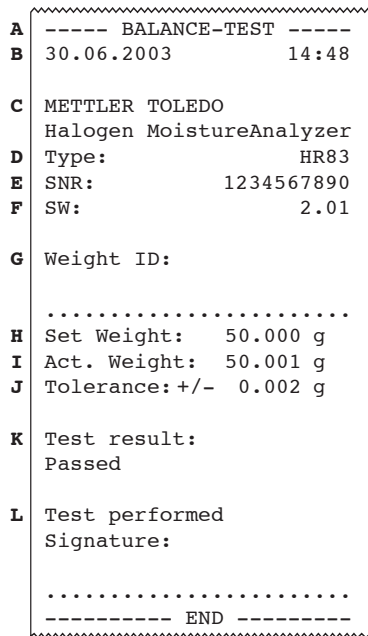

The balance test record contains the following information.

- A** Record title
- B** Date and Time of the record printout of the balance test
- C** Manufacturer and Designation of the instrument
- D** Type of the instrument
- E** Serial number of the instrument
- F** Version number of the software
- G** Field for entry of the number of the adjustment weight used
- H** Test weight used (= set weight)
- I** Recorded weight (= actual weight)
- J** Tolerance for the balance test (Section 6.22)
- K** Test result: "Passed" or "Failed"
- L** Field for signature of the person who performed the balance test



In the "W.CAL" menu you can print out the latest test record at any time by pressing the «Print» key. Only one original copy (with signature field) can be printed, however. The test record is only printed if the balance test was performed after the last balance adjustment.

6.4 Adjusting the heating module

In this menu item you can adjust the temperature control of the heating module. Consult Section 3.2 to learn when an adjustment of the heating module is necessary. We advise you to wait at least 30 minutes after a drying operation (or previous heating module adjustment) before performing the adjustment.

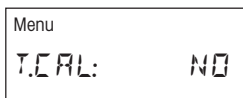

The factory setting in this menu item is "NO" (no heating module adjustment).

Note: The number above the word "NO" shows the number of adjustments performed to date.

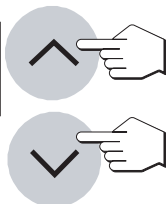
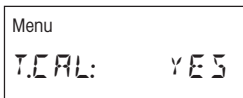

If you wish to adjust the heating module, select "YES" (using the «Scroll up» or «Scroll down» key).

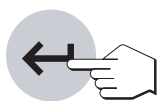

Press the «Accept entry» key to start the adjustment process. The sample chamber automatically opens and you are prompted to insert the temperature adjustment set.

Note: The temperature adjustment set is available as an accessory (see Section 9.9).

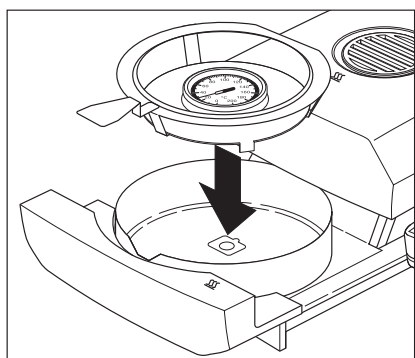

Remove the sample pan holder from the automatic sample chamber.

Place the temperature adjustment set (together with the sample pan handler) in the sample chamber.

Note: Ensure that your instrument is in a suitable location (see Section 2.2).



Press the «Start» key to initiate the adjustment process. The automatic sample chamber closes and the heating module adjustment starts.

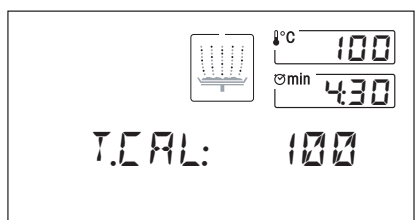

The heating module is heated to a temperature of 100 °C. You can follow this process in the temperature display. The instrument waits for 15 minutes until the temperature adjustment set is displaying the temperature correctly. At the end of this time a continuous audio signal sounds.

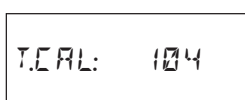

Read the temperature on the temperature adjustment set through the inspection window in the heating module and use the «Scroll up» and «Scroll down» keys (or the numeric keypad) to enter the value (NB: 1 graduation mark = 2 °C). After entering the value, press the «Accept entry» key. The temperature must be entered within 10 minutes of the audio signal sounding, otherwise the adjustment process will be terminated and an error message outputted.

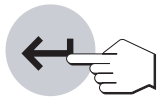
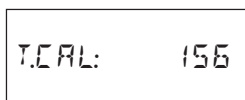

As this adjustment is a two-point adjustment (adjustment of the temperature is defined by two points, namely 100 °C and 160 °C), the heating module now heats to the second temperature (160 °C). Proceed exactly as you did for the first temperature. After you have confirmed your entry with the «Accept entry» key, the adjustment is at an end.

On completion of the adjustment, the sample chamber automatically opens and you can remove the sample pan handler with the temperature adjustment set.



Warning: The temperature adjustment set may still be hot. You should therefore allow it to cool down first before removing it from the sample pan handler.

On completion of the heating module adjustment, the instrument automatically quits the menu and returns to the standby mode. It is now ready for further measurements.

The adjustment record is printed out automatically:

```

A - DRYER UNIT ADJUSTM. -
B 30.06.2003      14:50

C METTLER TOLEDO
  Halogen MoistureAnalyzer
D Type:          HR83
E SNR:          1234567890
F SW:           2.01
G Dryer Unit adjustm.  43

H Adjustment set ID:
.....
I Temperature 100°C: 101°C
J Temperature 160°C: 162°C

K Adjustment performed
  Signature:
.....
----- END -----

```

A Record title

B Date and Time of the record printout of the heating module adjustment

C Manufacturer and Designation of the instrument

D Type of the instrument

E Serial number of the instrument

F Version number of the software

G Identification (consecutive number) of the heating module adjustment, allows assignment of the measurement record to the appropriate adjustment record

H Field for entry of the number of the temperature adjustment set used (number is printed on the set)

I Set and actual temperature for the first adjustment point

J Set and actual temperature for the second adjustment point

K Field for signature of the person who performed the heating module adjustment



Enter the number of the temperature adjustment set, sign the record and store it in a safe place. This assures traceability, one of the basic requirements of every quality assurance system.

In the "T.CAL" menu you can print out the latest adjustment record at any time by pressing the «Print» key. Only one original copy (with signature field) can be printed, however.

6.5 Testing the heating module

In this menu option you can test the temperature control on the heating module.

```

Menu
T.CAL:  NO

```

Check the heating module adjustment with TEST

The factory setting in this menu item is "NO" (no heating module adjustment).

```

Menu
T.CAL:  TEST

```



To check the last heating module adjustment at 100 °C and 160 °C, use the «Scroll up» or «Scroll down» keys to select "TEST". Press the «Accept entry» key to confirm your selection.

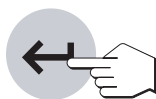
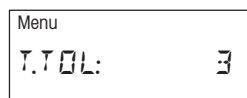

Choose the permissible tolerance (as defined by your company's quality management) for the heat output. With the HA-TCC temperature adjustment set, the HR83 can maintain a tolerance of +/- 3°C.

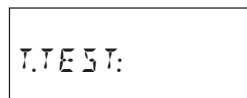

Press the «Accept entry» key to start the test procedure. The sample chamber opens automatically and you are prompted to insert the temperature adjustment set.



Note: Ensure that your instrument is in a suitable location (see Section 2.2).

Press the «Start» key to initiate the test procedure. The sample chamber closes and the test for the two-point heating module adjustment begins. Now proceed as for the standard two-point heating module adjustment.

The test record is printed out automatically.

The heating module test record contains the following information.

```

A --- DRYER UNIT TEST ---
B 30.06.2003      14:48
C METTLER TOLEDO
  Halogen MoistureAnalyzer
D Type:          HR83
E SNR:           1234567890
F SW:            2.01
G Adjustment set ID:
.....
H Set Temperature: 100 °C
I Act. Temperature: 101 °C
J Tolerance:      +/- 3 °C
K Set Temperature: 160 °C
L Act. Temperature: 161 °C
  Tolerance:      +/- 3 °C
M Test result:
  Passed
N Test performed
  Signature:
.....
                        END
    
```

- A** Record title
- B** Date and Time of the record printout of the heating module test
- C** Manufacturer and Designation of the instrument
- D** Type of the instrument
- E** Serial number of the instrument
- F** Version number of the software
- G** Field for entry of the number of the temperature adjustment set used (number is printed on the set)
- H** Set temperature (first temperature) for the test adjustment
- I** Actual temperature (first temperature) for the test adjustment
- J** Tolerance (this value enables the test to be graded as "Passed" or "Failed")
- K** Set temperature (second temperature) for the test adjustment
- L** Actual temperature (second temperature) for the test adjustment
- M** Test result: "Passed" or "Failed"
- N** Field for signature of the person who performed the heating module test



In the "T.CAL" menu you can print out the latest test record at any time by pressing the «Print» key. Only one original copy (with signature field) can be printed, however. The test record is only printed subsequently if the heating module test was performed after the last heating module adjustment.

Check the heating module adjustment with TEST-1

The purpose of this menu option is to check the heat output between 50 °C and 180 °C. The temperature for TEST-1 can be freely chosen within this range.

The factory setting in this menu item is "NO" (no heating module adjustment).

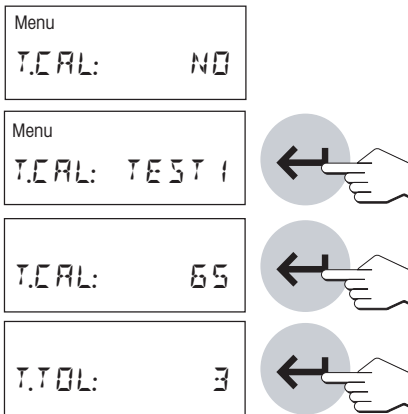

To test the heating module, use the «Scroll up» or «Scroll down» keys to select "TEST 1". Press the «Accept entry» key to start the test procedure. Enter the target temperature you require (e.g. 65 °C) and press «Accept entry». Then define the temperature tolerance and press «Accept entry» again.

The sample chamber automatically opens and you are prompted to insert the temperature adjustment set. Remove the sample pan holder from the automatic sample chamber and insert the temperature adjustment set in the sample pan handler. Place the sample pan handler in the automatic sample chamber.



Press the «Start» key to initiate the test procedure. The sample chamber closes and the test for the heating module adjustment begins. When the target temperature is reached (after a waiting time of 15 min) a continuous audio signal sounds. The actual temperature can be entered over a period of no more than 10 minutes.

To do this, read the temperature on the temperature adjustment set through the inspection window in the heating module and use the «Scroll up» and «Scroll down» keys (or the numeric keypad) to enter the value (NB: 1 graduation mark = 2 °C). Press the «Accept entry» key to confirm your input. The temperature must be entered within 10 minutes of the audio signal sounding, otherwise the adjustment process will be terminated and an error message outputted.

The test-1 record is printed out automatically.

The heating module test-1 record contains the following information.

```

A  -- DRYER UNIT TEST 1 --
B  30.06.2003           14:48

C  METTLER TOLEDO
   Halogen MoistureAnalyzer
D  Type:                HR83
E  SNR:                 1234567890
F  SW:                  2.01

G  Adjustment set ID:
   .....
H  Set Temperature:    65 °C
I  Act. Temperature:  66 °C
J  Tolerance:         +/- 3 °C

K  Test result:
   Passed

L  Test performed
   Signature:
   .....
   ----- END -----
    
```

- A** Record title
- B** Date and Time of the record printout of the heating module test
- C** Manufacturer and Designation of the instrument
- D** Type of the instrument
- E** Serial number of the instrument
- F** Version number of the software
- G** Field for entry of the number of the temperature adjustment set used (number is printed on the set)
- H** Set temperature for the test adjustment

- I Actual temperature for the test adjustment
- J Tolerance (this value enables the test to be graded as "Passed" or "Failed")
- K Test result: "Passed" or "Failed"
- L Field for signature of the person who performed the heating module test



In the "T.CAL" menu you can print out the latest test record at any time by pressing the «Print» key. Only one original copy (with signature field) can be printed, however. The test record is only printed subsequently if the heating module test-1 was performed after the last heating module adjustment.

6.6 Resetting to the factory settings

In this menu item you have the possibility to reset the basic settings of the instrument to the factory setting.



Warning! With the exception of the time, date and dialog language, all individual settings (incl. the method memory) you have made in the menu will be lost and replaced by the factory settings! Journal and statistics data will be deleted.

```
Menu
FCT.SET: NO
```

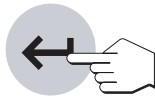

The factory setting in this menu item is "NO". If you really wish to delete your individual menu settings, select "YES" and confirm this with the «Accept entry» key.

```
Menu
FCT.SET: YES
```

```
Menu
ABORT?
```



For reasons of safety, you are again asked if you really wish to delete your data. You can abort the procedure at this point or delete the data, i.e. reset to the factory settings. Confirm your selection with the «Accept entry» key.

```
Menu
SET?
```

6.7 Clearing the method memory

The method memory contains the individual settings for your measurements (switch-off criterion, display mode, print interval, etc.) and the results of your measurements (statistics, journal). This menu item allows the method memory to be cleared. Your settings will be replaced by the factory settings and statistics and journal will be cleared.



Warning! If the method memory is cleared, you will lose all individual settings with the exception of the settings in the menu!

```
Menu
MCLR:  NO
```



The factory setting in this menu item is "NO". If you really wish to clear the method memory, select "YES" and confirm this with the «Accept entry» key.

```
Menu
MCLR:  YES
```

```
ABORT?
```

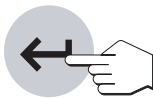

For reasons of safety, you are again asked whether you really wish to clear the method memory. You can abort the procedure at this point or clear the memory. Confirm your selection with the «Accept entry» key.

```
CLEAR?
```

6.8 Setting the time

In this menu item you enter the current time. This is necessary when putting your instrument into operation for the first time and for possible corrections (e.g. changeover from summer to winter time).

```
Menu 7
TIME: 13:04
```

Set the time with the «Scroll up» and «Scroll down» keys (or via the numeric keypad) (Range 00:00–23:59).

```
Menu 7
TIME: 16:28
```

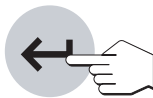

Confirm your setting with the «Accept entry» key and the instrument stores the time.

6.9 Entering the date

In this menu item you enter the current date. This is necessary when putting the instrument into operation for the first time and for possible corrections.

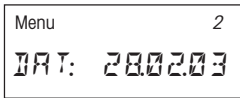

Set the date with the «Scroll up» and «Scroll down» keys (or via the numeric keypad) in the format "Day – Month – Year" (DD.MM.YY). Confirm your entry with the «Accept entry» key and your instrument stores the date.

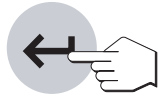

Note: If US English is used as the dialog language, the entry has the format "Month – Day – Year" (MM/DD/YY).

6.10 Setting the vibration adapter

You can use the vibration adapter to match your instrument to the ambient conditions at its location.

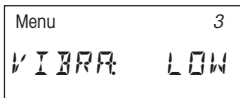

The following settings are available:

Setting for very stable ambient conditions. The instrument operates quickly but is sensitive to vibrations.



Setting for normal ambient conditions. This is the **factory setting**.

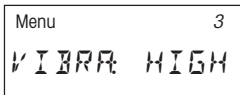

Setting for unstable ambient conditions. The instrument operates more slowly but is less sensitive to vibrations.

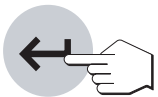

Select the appropriate setting and confirm your selection with the «Accept entry» key.

6.11 Selecting operating mode of the automatic sample chamber

In this menu item you can choose whether the automatic sample chamber should operate automatically or manually. Your instrument is set in the factory to the automatic operating mode. We advise you to use the manual operating mode for samples which contain readily volatile substances. In contrast to the automatic operating mode, in the manual operating mode the sample chamber does not automatically close when the «Start» key is pressed. However, the initial weight (wet weight) important for the determination of the moisture content is recorded. In the manual operating mode you have time for further preparation of the sample (e.g. mixing with quartz sand or even distribution of the sample) while weight losses due to evaporation during the preparation time are measured from the outset. As soon as the sample is ready for drying, press the key «Open/close auto sample chamber». The automatic sample chamber closes and drying starts. In the manual operating mode you yourself can open the sample chamber during a drying operation e.g. in standby mode (Section 5.4.5). In contrast to the automatic mode, drying will not be stopped but simply interrupted until the automatic sample chamber is closed again.

```
Menu 4
START: AUTO
```

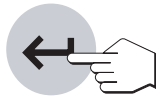

The factory setting in this menu item is "AUTO." (automatic operating mode). If you wish to switch to the manual operating mode, select "MAN." and confirm this with the «Accept entry» key.

```
Menu 4
START: MAN
```

6.12 Audio signal

Many processes are signalled by an audio signal (e.g. end of drying, entries, error messages, etc.). In this menu item you can select whether the audio signal should be loud, soft or switched off.

```
Menu 5
BEEP: OFF
```

The following settings are available:

No audio signal

```
Menu 5
BEEP: LOW
```

Soft signal (**Factory setting**)

```
Menu 5
BEEP: HIGH
```

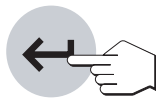

Loud signal

Select the desired setting and confirm with the «Accept entry» key.



Note: The alarm clock symbol in the display indicates that an audio signal has been activated in the menu.

6.13 Protecting your settings against change

You can protect the settings of your methods parameters (e.g. switch-off criterion, drying temperature, etc., see Section 4) and the settings in the Methods menu (Section 5.4) against change by locking the appropriate keys for entries. This also protects the statistics and the journal against clearance. Alternatively you can work with a password which protects your method settings if the system is restored to factory settings (see Section 6.1).

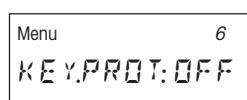

The instrument is set in the factory to allow the parameters to be changed ("PROT: OFF").

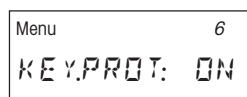

If you wish to protect the settings against change, selection "PROT: ON" and confirm this with the «Accept entry» key.



The display shows the padlock symbol and the following settings can then no longer be changed:

- Switch-off criterion
- Drying program
- Display mode
- Print interval
- Drying temperature
- Drying time
- Target weight of the weighing-in aid
- All settings in the Methods menu (Section 5.4)

If you press one of the locked keys, an audio signal and an error message (see Section 8.2) draw your attention to the nonavailability of the corresponding function.

6.14 Superimposing or removing the function symbols

In this menu item you can select whether the function symbols should always be visible or only when needed. In routine operation, the display is easier to survey if the symbols are faded out.

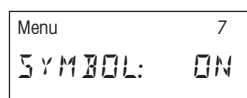

In the factory the symbols are switched on ("ON").

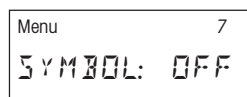
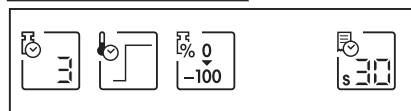

If you wish to switch off the symbols, select "OFF" and confirm this with the «Accept entry» key.

Note: If you switch off the function keys, they will be displayed for around 30 seconds when the instrument is switched on and then faded out. If one of the function keys is pressed, the function symbols will be shown immediately and then faded out again 30 seconds after a function key has last been pressed.

6.15 Switching the printer on or off

In this menu item you can switch the built-in printer on or off.

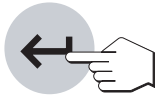

In the factory this item is switched on ("ON").

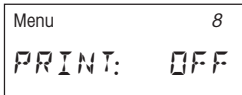

If you wish to switch the printer off, select "OFF" and confirm this with the «Accept entry» key.

6.16 Entering company name for printed records

In this menu item you can define whether the name of your company (or any other text, e.g. the name of the department) should appear at the very top of the printout in the record header. There are two lines available.

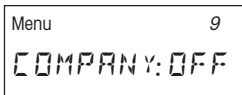

In the factory this item is switched off ("OFF").

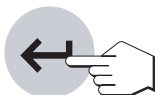
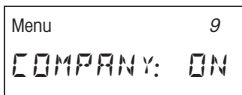

If you wish to print your company name, select "ON" and confirm this with the «Accept entry» key.



Now enter the name: press the «A...Z» key. A flashing "A" appears at the first input position on the extreme left and signals that the instrument is ready for your entry.



You can now use the «Scroll up» and «Scroll down» keys to select the first letter of the name (uppercase letters only) or special characters (+, -, etc.).



Confirm your selection with the «A...Z» key. The flashing "A" now reappears, but at the second position.

Enter the remaining characters of the desired name (up to 20 characters) as described above.

Notes

- A space is symbolized by the underline character " _ ".
- You can remove wrong characters with the «Delete» key and then correct your entry.



- Numbers can be entered directly via the numeric keypad. If you enter a character via the numeric keypad, the instrument remains in numeric input mode and a flashing dash appears at the next input position instead of a flashing "A". To switch back to the text mode, press the «A...Z» key again.

```

SAMPLE LTD
  
```



As soon as you have finished entering the name, press the «Accept entry» key.

```

CENTRAL LABORATORY
  
```



If you wish you can enter a department name, for example, in a second line: press the «Accept entry» key.

The inputted name appears with immediate effect on the record assuming you have selected the full record (see next Section).

6.17 Selecting the type of record

In this menu item you decide the length and hence the extent of detail of the measurement records.

```

Menu          10
RECORD: NORM
  
```



In the factory setting, normal records ("NORM.") are printed out. You will find the normal record explained in Section 4.9.

```

Menu          10
RECORD: FULL
  
```

If you wish for more detailed measurement records, select "FULL" and confirm this with the «Accept entry» key.

Specifications for the design of the measurement record can be found in Section 4.9.

6.18 Defining the free print interval

You became familiar with the preselected print intervals in Section 4.6. If the preselected values are not suitable for your application, you can define a free print interval in this menu item.

```

Menu          11
F.PRT.IN: OFF
  
```

In the factory the free print interval is deactivated ("OFF").

```

Menu          11
F.PRT.IN: ON
  
```



If you wish to define a free print interval, select "ON" and confirm this with the «Accept entry» key.

```

Menu          11
PRT.IN: 15:00
  
```



Now enter the desired print interval using the «Scroll up» and «Scroll down» keys or the numeric keypad (between 5 seconds and 60 minutes). Confirm your entry with the «Accept entry» key.



The free print interval is now available with its own symbol under the function key «Print interval».

6.19 Switching the statistics and journal functions on and off

If you do not wish to use the statistics and journal functions (see Section 5), you can switch them off in this menu option. This makes it easier to use the instrument if you are working with only one type of sample and therefore do not require the features of the statistics and journal functions.

```
Menu      12
ST/JOU   ON
```

The statistics and journal functions are switched on as the factory setting ("ST/JOU: ON").

```
Menu      12
ST/JOU   OFF
```

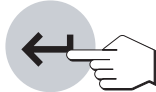

To switch off the statistics and journal functions choose "ST/JOU: OFF" and confirm by pressing the «Accept entry» key.

```
Menu
ABORT?
```

When you press the «Accept entry» key, the prompt "ABORT?" or "CLEAR?" appears. Choose "CLEAR" and press «Accept entry» to confirm.

```
Menu
CLEAR?
```

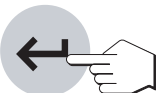

The features of the statistics and journal functions are no longer available to you.

6.20 Selective clearing of comment lines

In this menu you can clear the existing comment lines (see Section 4.8). In routine operation it is often the case that individual comment lines can be retained for several measurements. On the other hand you need to prevent comment lines (compulsory measurement inputs) from being accidentally included from an old measurement. You can therefore activate automatic clearing after each measurement for all or individual comment lines.

```
Menu      13
CCLR:    1-4
```

The factory setting in this menu option is "1-4".

```
Menu      13
CCLR:    2-4
```



To clear comment lines after each measurement, use the «Scroll up» and «Scroll down» keys to select "YES". Press the «Accept entry» key to confirm your setting.

```
Menu      13
CCLR:    3-4
```



You can then specify which comment lines you wish to be cleared after each measurement. Use the «Scroll up» and «Scroll down» keys to choose the comment lines you wish to be cleared. The options are:

```
Menu      13
CCLR:    4
```

C.CLR: 1-4 All 4 comment lines automatically cleared

C.CLR: 2-4 Comment lines 2-4 automatically cleared

C.CLR: 3-4 Comment lines 3-4 automatically cleared

C.CLR: 4 Comment line 4 automatically cleared

C.CLR: NO No automatic clearing of comment lines

```
Menu      13
CCLR:    NO
```



Press the «Accept entry» key to confirm your setting.

6.21 Defining the test weight

You learnt about checking the balance adjustment in Section 6.4. In this menu option you can specify the target weight for the test.

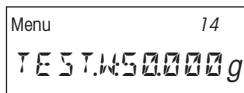

The factory setting in this menu option is "50.000 g".



To define a test weight, choose menu option 14. You can then define a new test weight between 0.100 g and 80.000 g via the numeric keypad and press the «Accept entry» key to confirm.

6.22 Tolerance for balance test

In this menu option you can define the tolerance range. This value is used to calculate whether the balance test is "Passed" or "Failed" (difference calculation).

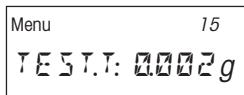

The factory setting in this menu option is "0.002 g".

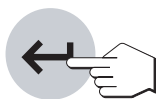

To define a tolerance range, choose menu option 15. You can then define a new tolerance range between 0.001 g and 0.010 g via the numeric keypad and press the «Accept entry» key to confirm.

6.23 Selecting the dialog language

In this menu item you specify the dialog language.

Menu
DEUTSCH



Menu
FRANCAIS

Menu
ITALIANO

Menu
ESPAÑOL

Menu
RUSSIAN

Menu
ENGLISH EU

Menu
ENGLISH US

Select the desired dialog language and then confirm your entry with the «Accept entry» key.

The following languages are available:

- German (“Deutsch”)
- French (“Français”)
- Italian (“Italiano”)
- Spanish (“Español”)
- Russian (“Russian”)
- British English (“English EU”)
- American English (“English US”)

Note: If you select American English (“English US”) as the dialog language, the date format is changed and appears on all records in the American notation (month/day/year).

7 Servicing and replacing individual parts

In this Section you will learn how to keep your Moisture Analyzer in good condition and how to replace expendable parts. You also find information on how to check the printer and change the printer paper and ribbon.

7.1 Cleaning

To obtain precise measurement results, we advise you to clean the temperature sensor and the protective glass of the heating modules at regular intervals. Please note the following directions for cleaning your instrument:

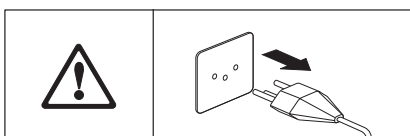

Disconnect the instrument from the power supply before cleaning.

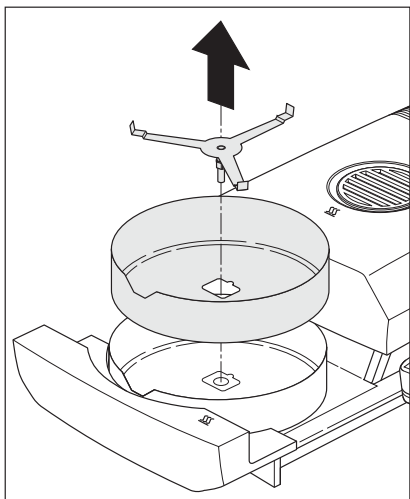

Open the automatic sample chamber by pulling it out.
 Remove the draft shield element and the sample pan holder before cleaning.
 Use a lint-free cloth for cleaning.

Clean the exterior of the instrument and the drying compartment with a mild cleaning agent. Although the housing is extremely rugged and resistant to solvents, never use abrasive cleaning agents or solvents!

Ensure that no liquid enters the interior of the instrument.

To clean the temperature sensor and the protective glass of the heating module, you should first open the heating module as described in Section 7.6.

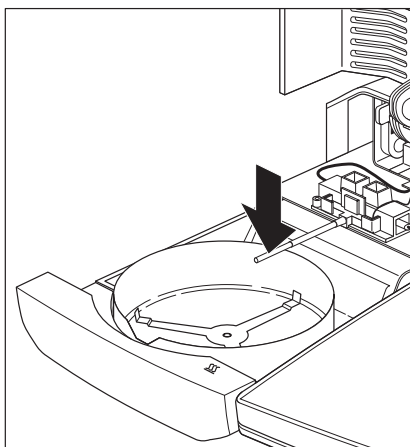

Carefully remove any deposits from the black temperature sensor.

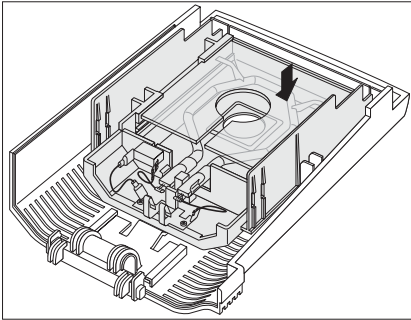

To clean the protective glass of the heating module, dismantle the heating module (see Section 7.6), place it on a flat work surface and clean the protective glass with a commercial glass cleaner.

The air inlet of the fan is located at the rear of the instrument and its exterior should be cleaned from time to time to free it from any dust deposits.

After the temperature sensor and/or the protective glass have been cleaned, we recommend adjusting the heating module (Section 6.4).

7.2 Changing the printer paper and ribbon

Apart from the need to replace the printer paper and ribbon on occasion, the built-in printer requires no maintenance.

Changing the printer paper

The printer paper is changed as follows:

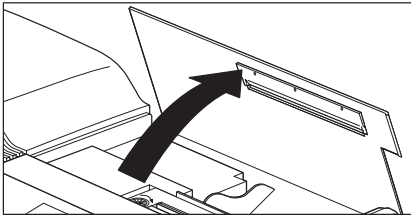

Open the cover of the built-in printer.

Pull any remaining paper upwards out of the printing unit.

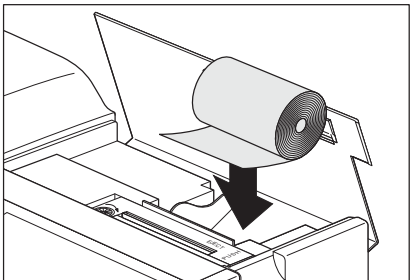

Insert a new roll of paper in the paper compartment and feed the paper horizontally through the slot at the back of the printing unit.



Press the «Paper feed» key until the leading edge of the paper exits the printing unit at the top.

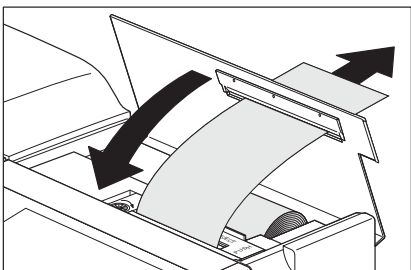

Lead the paper through the slot in the cover of the built-in printer and close the cover.

Replacing the ribbon

When the print quality deteriorates, replace the ribbon as follows:

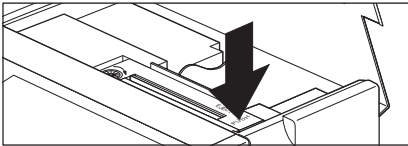

Open the cover of the built-in printer and press the projection marked "PUSH" on the right of the ribbon cassette.

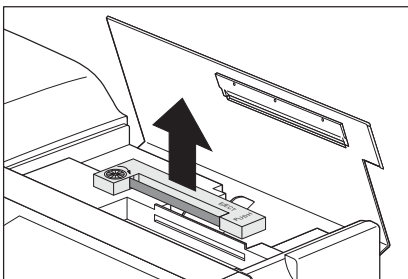

Pull the ribbon cassette up and out of the instrument and insert the new cassette. Thread the paper between the ribbon and the cassette. Press the cassette down as far as it will go until you hear it click into place.

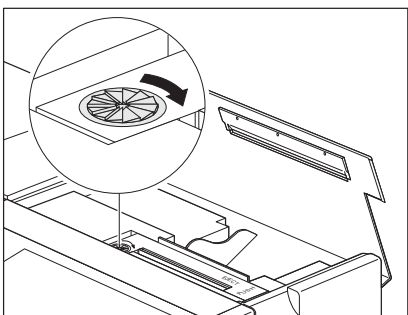

Tension the ribbon by turning the small wheel on the left of the cassette in the direction shown by the arrow. After you have tensioned the ribbon, close the cover of the printer.

Used ribbons must be disposed of in accordance with applicable customer and national regulations.

7.3 Replacing the power line fuses

If the display of your instrument remains "dark" after switching on, in all probability the power line fuses of the instrument are blown.

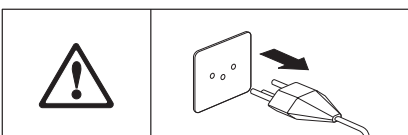

To change the fuses, proceed as follows:

Disconnect the instrument from the power supply.

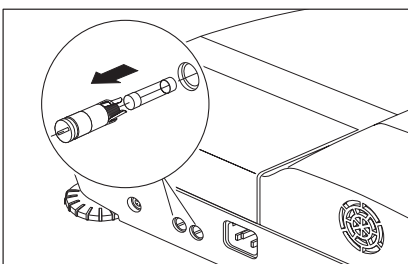

The two power line fuses (for neutral and phase) are located at the rear of the instrument. Turn the two fuse holders with a screwdriver to the left and pull the fuse holders out of the instrument.

Check the condition of **both** fuses. Replace blown fuses by those of the same type with the same rated value (5 x 20 mm, T6, 3H 250 V).



The use of fuses of a different type or with different values as well as the bridging of fuses is not allowed and can hazard your safety and lead to instrument damage!

7.4 Printer test

Your instrument has a function to check the proper functioning of the built-in printer.

Ensure that the instrument is switched off.

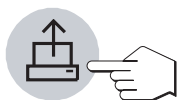

Press and hold the «Paper feed» key while simultaneously switching the instrument on with the «On/Off» key. The printer prints out its complete character set.



To stop the test, switch the instrument off with the «On/Off» key.

7.5 Installing the built-in printer

If your instrument is not already fitted with a built-in printer, you can order a printer as an option and retrofit it at any time. You can also change the built-in printer yourself without any problems should this be necessary. The procedure for installing the built-in printer is described in the **11780558** you received with the printer.

7.6 Dismantling and replacing the heating module

If a fault arises, the complete heating module can be replaced. We also advise you to open or dismantle the heating module to clean the protective glass of the heating module (see Section 7.1).

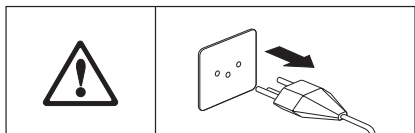

Disconnect the instrument from the power supply and be sure to allow the heating module to cool down for 10 minutes before you start the work!

The heating module is released by withdrawing the automatic sample chamber 2-3 cm.

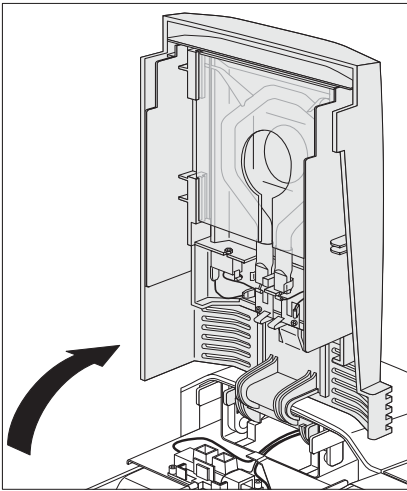

Swing the heating module upward.

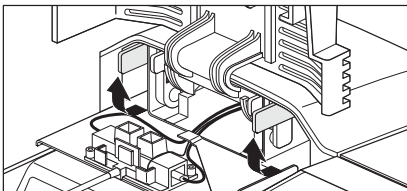

Disengage the hinge of the heating module by turning the two yellow levers 90° forward.

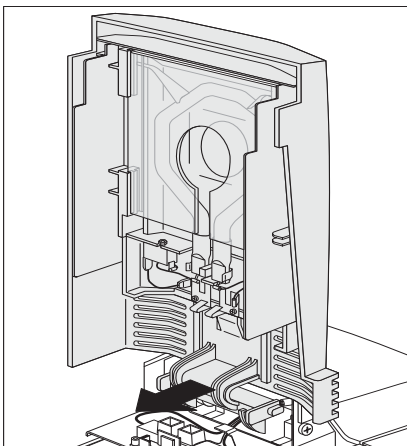

Remove the heating module (pull forward).

Install the (new or cleaned) heating module in the instrument and lock the hinge with the two yellow levers.

After a heating modules has been cleaned or replaced, we recommend re-adjusting the heating module of your Halogen Moisture Analyzer (Section 6.4).

Defective parts must be disposed of in accordance with applicable customer and national regulations.

8 If problems arise on occasion

In this Section you will learn how errors can appear during operation of your Moisture Analyzer and how you can rectify these errors.

8.1 Notes on the error messages

Your instrument distinguishes between the three different types of errors explained below.



Input errors (key not active or can not be pressed in current operating status) are reported by your instrument with a short audio signal (if activated in the menu) without an error message in the display.

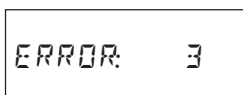

An **application error** occurs when the instrument can not perform a procedure or a corrective action is necessary as the limits of a value range have been violated or because a general operating error exists. Application errors are reported by your instrument with an audio signal. Further, the message "ERROR" appears in the display followed by the error number. You will find a list of all application errors in the next Section.

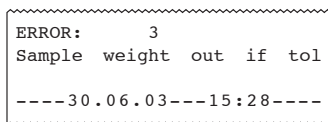

If your instrument is equipped with a built-in printer, you can print the error message **in clear text** with the «Print» key.

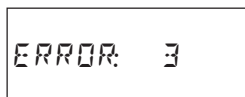

Before you can continue working, you must delete the error message with the «Reset» key.

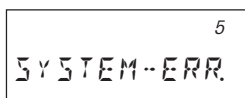

System errors indicate that a program or hardware error exists. The message "SYSTEM-ERR." appears in the display and the error number is shown in the top right corner. In such a case, disconnect the instrument from the power supply. Should the error reappear after reconnection to the power supply, contact your METTLER TOLEDO dealer to arrange an appointment for diagnosis and repair. Note the error number in order to facilitate the work of the service engineer.

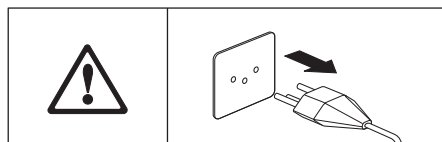

8.2 Meaning of the error messages

In this Section you will find all error messages which appear in the display, the text of the error record on the printer, the reason for the error message and directions on how to rectify the error.

<pre>ERROR: 1</pre>	<p>Display: Error: 1</p> <p>Printout: Weighing result unstable</p> <p>Cause: No stability during taring or adjustment</p> <p>Remedy: Ensure stable ambient conditions and an optimum location. Also take care that no part of the sample or the sample pan touch the draft shield element or the sample pan holder. Highly volatile substances in the sample also prevent a stable weighing result being detected.</p>
<pre>ERROR: 2</pre>	<p>Display: Error: 2</p> <p>Printout: Wrong calibration weight</p> <p>Cause: No or wrong adjustment weight loaded</p> <p>Remedy: Load required adjustment weight</p>
<pre>ERROR: 3</pre>	<p>Display: Error: 3</p> <p>Printout: Sample weight out of tol</p> <p>Cause: Sample weight below 100 mg or outside the set limits with the weighing-in aid active (Section 4.7).</p> <p>Remedy: Weigh in a sample of at least 100 mg, adjust the sample weight so that it is within the set limits or deactivate the weighing-in aid.</p>
<pre>ERROR: 4</pre>	<p>Display: Error: 4</p> <p>Printout: Missing tare weight</p> <p>Cause: Sample vessel has not been tared</p> <p>Remedy: Tare sample vessel</p>
<pre>ERROR: 5</pre>	<p>Display: Error: 5</p> <p>Printout: Entry inadmissible</p> <p>Cause: Lower/ upper limit of input range violated. For the «Target» key: Test measurement (switch-off criterion function key) is not activated. Taring or weighing in has not yet been performed.</p> <p>Remedy: Enter value in valid range. For the «Target» key: Activate test measurement ("T") (Section 4.12). Tare and weigh in sample.</p>

ERROR: 6

Display: Error: 6
Printout: Not activated in menu
Cause: Keypad has been locked in menu, printer deactivated in menu
Remedy: Remove keypad locking, activate printer in menu

ERROR: 7

Display: Error: 7
Printout: Timer not activated
Cause: The selected switch-off criterion does not allow entry of a time
Remedy: Select "Timed switch-off" as switch-off criterion

ERROR: 8

Display: Error: 8
Printout: Entry missing
Cause: In the heating module adjustment, the wait time of 10 minutes for entry of the temperature value has been exceeded
Remedy: Repeat heating module adjustment and enter temperature values before elapse of the wait time

ERROR: 9

Display: Error: 9
Printout: Function error
Cause: Undefined condition
Remedy: Press «Reset» key or briefly switch instrument off then on again with the «On/Off» key. If this error appears in the calibration, please contact your METTLER TOLEDO dealer

ERROR: 10

Display: Error: 10
Printout: Temperature > Start-Temp.
Cause: Sample chamber has not cooled down sufficiently or the standby temperature (Section 5.4.5) was set higher than the drying temperature
Remedy: Allow the instrument to cool down to the starting temperature or reduce the standby temperature

ERROR: 11

Display: Error: 11
Printout: PW: Wrong entry
Cause: Password was entered incorrectly
Remedy: Enter password correctly



Display: Error: 12
 Printout: Password protection PW-1
 Cause: The method parameters are protected by a password (PW-1)
 Remedy: Reset password PW-1, change the methods and set a new PW-1

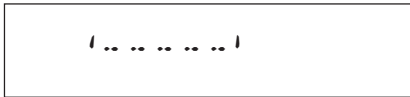

Display: | _ _ _ _ |
 Cause: Underload
 Remedy: Load the sample pan holder

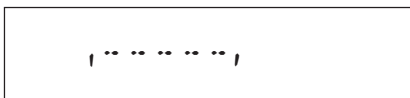

Display: | _ _ _ _ |
 Cause: Overload
 Remedy: Decrease the weight of your sample

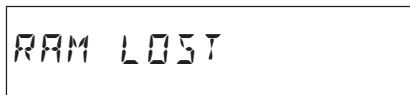

Display: RAM LOST
 Cause: The installed battery is discharged (the equipment was disconnected from the power supply for a longer period) or the instrument is faulty
 Remedy: Charge battery (connect instrument to the power supply for 5 hours) and then reenter all settings. If the error reappears, contact your METTLER TOLEDO dealer.

8.3 What if...?

... the display remains "dark" after switching on?

- no line voltage
- power cable not connected
- blown power line fuses
- instrument faulty

Ensure that the instrument is connected to the power supply and that power supply is actually supplied. Check the power line fuses of the instrument and replace if necessary (see Section 7.3). If the instrument still refuses to function, contact your METTLER TOLEDO dealer.

... after switching on "0.000" flashes in the display?

The sample pan holder is not installed. Install the sample pan holder.

... the function symbols disappear from the display after a certain time

You have deactivated the symbols in the menu (see Section 6.14).

... the symbol of the stability detector is continuously lit up immediately after the start?

As soon as the symbol of the stability detector fades, the weighing result is stable and is accepted as a "wet weight". If the symbol does not fade, your instrument is probably at an unsuitable location (vibrations, shocks, powerful drafts, etc.). Seek a more suitable location.

Samples containing readily volatile substances may never reach stability owing to continuous evaporation. In this case, you must select manual operation for the automatic sample chamber (see Section 6.11).

... the built-in printer does not print?

Ensure that the printer is activated in the menu (see Section 6.15) and that the ribbon and paper are correctly installed. If the printer still refuses to print, perform a printer test (see Section 7.4). If the test is unsuccessful, contact your METTLER TOLEDO dealer.

... no drying time can be entered?

Entry of the drying time is possible only if you have selected the switch-off criterion "Timed switch-off", with all other switch-off criteria this input possibility is not available (see Section 4.4). If you attempt to enter a drying time, the instrument reports "Error: 7" (see Section 8.2).

... certain keys are inactive?

You have protected the parameters (switch-off criterion, print interval, etc.) in the menu against change (see Section 6.13). If you attempt to change a parameter, the instrument reports "Error: 6" (see Section 8.2).

... an error message appears when I press certain keys?

You have entered an illegal value or you have activated password PW-1 in the menu, see Error messages (see Section 8.2).

... the measurement takes too long?

You have selected an unsuitable switch-off criterion. The suitable switch-off criterion is simple to determine by a test measurement. You will find information on how to perform a test measurement in Sections 4.4 and 4.11.

An excessive amount of sample can also be the cause of slow drying, likewise samples which tend to form a skin which hinders vaporization.

Perform experiment at higher temperature.

... the weighing-in aid is not visible?

The weighing-in aid is available only if you have activated (see Section 4.7).

... the automatic sample chamber does not close after pressing «Start»?

You have selected the manual operating mode in the menu (see Section 6.11).

... the device switches off?

The method you are using called for a standby temperature, and you have activated the standby time or standby switchoff time (Section 5.4.5.1).

... the device begins to heat up when it is switched on or when the method is changed?

The method you are using called for you to activate the standby temperature (Section 5.4.5.1).

... the instrument does not heat following the start?

The heating module is overheated and the thermal overload protection has responded. The instrument is equipped with thermal overload protection (bimetallic sensor) which switches off the heating tube if overheating occurs. If this happens, the device must be reset. To do this, proceed as follows:

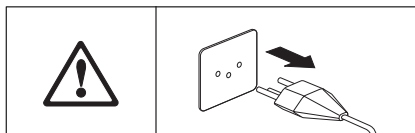

Disconnect the instrument from the power supply and be sure to allow the heating module to cool down for 10 minutes before you start the work.

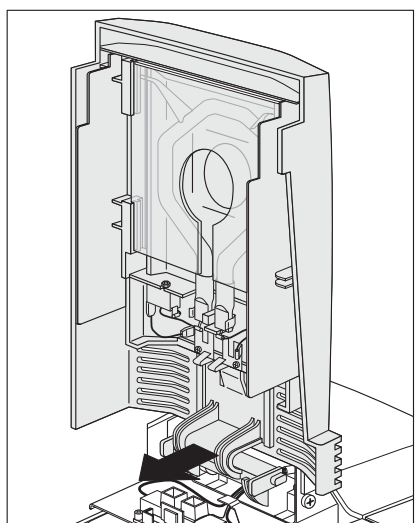

The heating module is released by withdrawing the automatic sample chamber 2-3 cm.

Swing the heating module upward.

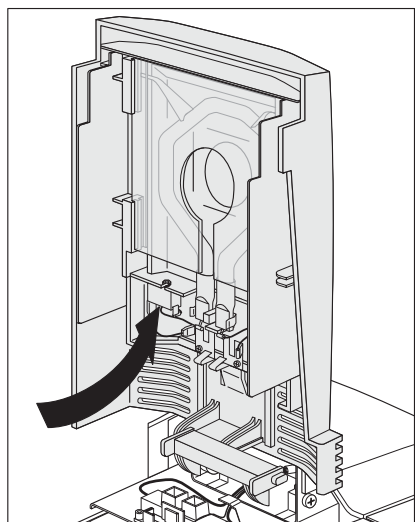

The thermal overload protection is reset by pressing the rear part of the white temperature switch.

The Analyzer can be restarted after closing the cover and connecting the instrument to the power supply.

Note: If this is not possible, there may be a fault (e.g. a faulty halogen heating module). In such a case, contact your METTLER TOLEDO dealer.

After the temperature switch is reset or a heating module replaced (Section 7.6) we recommend that you readjust the heating module of your Halogen Moisture Analyzer (Section 6.4).

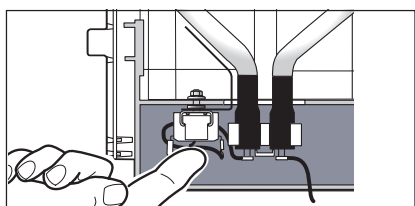

... the measurement results are not repeatable?

- The samples are not homogeneous, i.e. they have different compositions. The more inhomogeneous a sample, the larger the amount of sample needed to obtain a repeatable result.
- You have selected a drying time that is too short. Extend the drying time or select a suitable switch-off criterion “Weight loss per unit of time”.
- The sample does not become completely dry (e.g. owing to skin formation). Dry the sample with the aid of glass fiber filters (Section 3.3).
- You have selected a temperature that is too high and the sample has oxidized. Lower the drying temperature.
- The sample boils and the splashed drops continuously change the weight. Lower the drying temperature.
- You selected high resolution in the Methods menu, and set a standby temperature, but did not wait the recommended 15 minutes before taking your first measurement (preheating). Wait the recommended time.
- You are working with an extremely high-volatile sample, but you did not select the manual start. Select manual start for such samples.
- The sample was not prepared in the best possible way. Check that the samples are being stored properly, review the work process, make sure the samples are distributed evenly over the entire sample pan, etc.
- Insufficient heating power as the protective glass is dirty. Clean the protective glass (Section 7.1).
- The temperature sensor is contaminated or faulty. Clean the temperature sensor (see Section 7.1) or have it replaced by a service engineer.
- The support on which the instrument is standing is not sufficiently stable. Use a stable support.
- The instrument is not stable on its 4 feet.
- The surroundings are very unstable (vibrations etc.).

9 Further useful information

9.1 Notes on interpretation of the measurement results and the ideal sample weight

The accuracy of the measurement results depends on the wet weight and the original moisture of the sample. The relative accuracy of the measurement result improves with increasing wet weight. While the moisture of the sample is fixed, the weight of the sample can frequently be determined by the user. However, with increasing weight the drying process is lengthened. **We thus advise you to select the weight of your sample to obtain the repeatability you require.** You can use the following table to determine the ideal weight for your sample. The table does not include the scatter due to the sample and its preparation.

An example will suffice: A result with a repeatability of $\pm 0.1\%$ is expected. As the following table shows, your sample should have a minimum weight of 2 grams.

Repeatability of the result	Minimum sample weight
$\pm 0.02\%$	10 g
$\pm 0.05\%$	4 g
$\pm 0.1\%$	2 g
$\pm 0.2\%$	1 g

9.2 LocalCAN universal interface

Your Moisture Analyzer is fitted with a modern LocalCAN universal interface. This universal interface allows your instrument to interchange data with a computer or a control system. METTLER TOLEDO LC-P43 and LC-P45 printers can also be operated via this interface. The content and format of the printouts are the same as those produced by the optional built-in printer HA-P43.

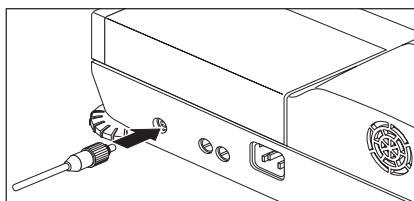

Devices (e.g. a computer) with an RS232 serial interface (with a DB9 or DB25 connector of the type usually found with PCs and laptops/notebooks) can be attached with the optional interface cables (LC-RS9 or LC-RS25, see Section 9.9).

For interface commands please refer to the "Reference Manual METTLER TOLEDO Standard Interface Command Set" 1 1780559, available from your METTLER TOLEDO dealer or download from the Internet (www.mt.com/moisture). More Information please find in the Section 9.8.

Data of the LocalCAN universal interface

- Cable length between two devices maximum 10 m
- Total of cable lengths of all attached devices maximum 15 m

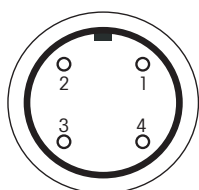
**Pin assignment**

Pin No.	Signal
1	negative signal line (-CAN)
2	positive signal line (+CAN)
3	plus pin of supply (V CAN) for peripherals
4	minus pin of supply (0 V) for peripherals

9.3 Barcode Reader

You can also connect an RS232 barcode reader to the existing LocalCAN universal interface (see Section 9.9). All alphanumeric entries (comment lines, company name, method names) can be made using the Barcode Reader if you wish.

To connect the bar code reader, you need the interface cable LC-RS9 (RS232/9-pin) order no. 229065, and cable RS 0.3 m (M-M X), order no. 21900924. Set the switches on the LC-RS9 box as follows: 4 / 3 / 0 (left to right).

9.4 Application brochure

The application brochure for moisture determination from METTLER TOLEDO (order number: 11795011) contains a great deal of useful information for optimum utilization of your Moisture Analyzer. To order your personal copy, please contact your METTLER TOLEDO dealer.

Example methods and applications can be found at www.mt.com/moisture.



Moisture determination applications must be optimized and validated by the user according to local regulations. Application-specific data provided by METTLER TOLEDO is intended for guidance only.

9.5 Switch-off criterion "Weight loss per unit of time"

With the switch-off criterion "Weight loss per unit of time", drying is automatically ended as soon as the **mean** weight loss (Δg in mg) per unit of time (Δt in seconds) drops below a preset value. 5 levels are preprogrammed in the factory each with a fixed weight loss per unit of time.

Further, a "Free switch-off criterion" allows you to define the weight loss per unit of time yourself.

The following applies to the individually selectable levels:

	Δg in mg	Δt in seconds
Switch-off criterion 1	1 mg	10 seconds
Switch-off criterion 2	1 mg	20 seconds
Switch-off criterion 3	1 mg	50 seconds
Switch-off criterion 4	1 mg	90 seconds
Switch-off criterion 5	1 mg	140 seconds
Switch-off criterion "F" (free)	1 mg to 10 mg	5 seconds to 3 minutes

The graph below exemplifies the mode of operation of the switch-off operation (not to scale).

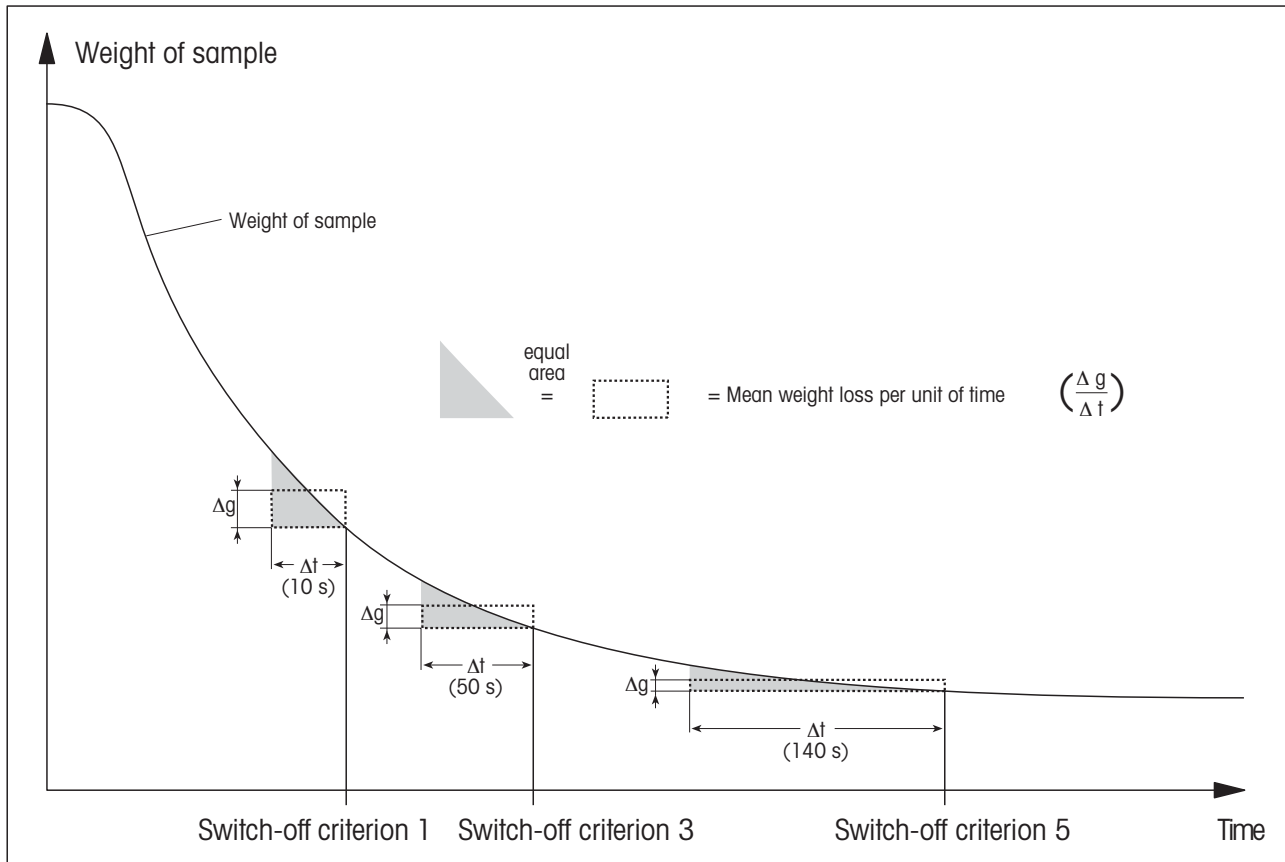

Key:

Switch-off criterion 1 (rapid availability of the result, suitable for determination of a trend)

Switch-off criterion 3

Switch-off criterion 5 (suitable for precision measurement)

9.6 Comments on certified version

Approval of the built-in balance is to EN45501 (OIML R76) requirements. When the heating module is switched off, the balance meets the applicable requirements of accuracy class 1. The metrological data are given on the certification plate (rear panel of instrument).

Adjustment of the built-in balance

Before adjustment of the balance, a wait time of 15 min. (following completion of the last heating cycle) assures compliance with the calibration tolerance limits following EN45501 (OIML R76).

9.7 Technical data

Please note that the Moisture Analyzer will undergo continuous further development in the interest of the users. METTLER TOLEDO thus reserves the right to change all technical data at any time and without prior notification.

Dryer

Heating module:	Halogen ring-shaped radiator
Temperature range:	40–200 °C
Temperature step:	1 °C
Heating module adjustment:	with temperature adjustment set HA-TC or HA-TCC
Heating module test:	with variable test points

Balance

Minimum sample weight:	0.1 g
Maximum sample weight: ¹⁾	81 g
Balance adjustment:	with external weight, 50 g ± 0.1 mg
Weighing test:	with variable test weight
Units:	g, % moisture content, % dry content, ATRO moisture content, ATRO dry content
Stability detector:	with symbol in display
Resolution of the balance:	1 mg / 0.1 mg
Readability of the result:	0.01% / 0.001%
Repeatability (sd) with 2 g sample: ²⁾	0.05%
Repeatability (sd) with 10 g sample: ²⁾	0.01%

Data

Time, date:	system clock, fail safe
Drying time:	manual, 30 seconds to 480 minutes
Operational settings:	read-only memory, fail safe
Switch-off criteria:	5 levels, manual, timed, test, free
Method memories (fail safe):	40
Drying programs:	Standard-, Fast-, Gentle- or Steps drying
Sample identification (4 separate lines):	alphanumeric, 20 characters each
Company and department name:	alphanumeric, 20 characters each
Reset protection:	by locking the keypad or with the 3-level password
Weighing-in aid (target weight):	0.1–81 g in 0.1 g steps
Limit values weighing-in aid:	1–25% (1% steps)
Standby temperature:	40–100 °C, programmable switch-off

¹⁾ Data for standard sample pan (diameter 90 mm), with the reusable sample pan the maximum sample weight is 50 g.

²⁾ Instrument acclimatized in room and connected to power supply for 30 minutes, drying temperature 160 °C.

Evaluation

Display modes:	5 modes (moisture, dry content, weight, ATRO moisture content, ATRO dry content = MC, DC, g, AM, AD)
Journal (fail safe):	last 20 measurement results per method
Statistics (fail safe):	continuous, per method (recording of 9999 messages maximum)
Records:	via built-in printer (Option)

Hardware

Audio signal:	adjustable (soft, loud, off)
Data interface:	LocalCAN universal interface built in, RS232C option
Inspection window:	in heating module
Leveling:	3 leveling screws and level indicator
Display:	LCD, supertwist LCD with backlighting
Status display (user guide):	integrated in display
Alphanumeric entry key:	integrated in keypad
Numeric entry keys:	integrated in keypad
Sample pan, \varnothing :	90 mm
Thermal overload protection:	bimetallic-element switch in heating module
Dimensions (w x h x d):	36 x 11 x 34 cm
Weight, ready to measure:	7.7 kg (with built-in printer)

Admissible ambient conditions

	Use only in closed rooms
Height up to:	4000 m
Temperature range ³⁾ :	5 °C to 40 °C
Atmospheric humidity:	80% RH @ to 30 °C
Voltage fluctuations:	-15%+10%
Installation category:	II
Pollution degree:	2

Power load:	Max. 450 W during drying process
Current consumption:	4 A or 2 A, according to the heating module
Power supply voltage:	100 V – 120 V or 200 V – 240 V, 50/60 Hz (the voltage is given by the heating module)
Power line fuse:	2 (in each conductor), 5 x 20 mm, T6,3H 250 V

³⁾ For drying temperatures below 50 °C the permissible range for ambient conditions is 5 °C to 30 °C (instead of 5 °C to 40 °C).

Dimensions

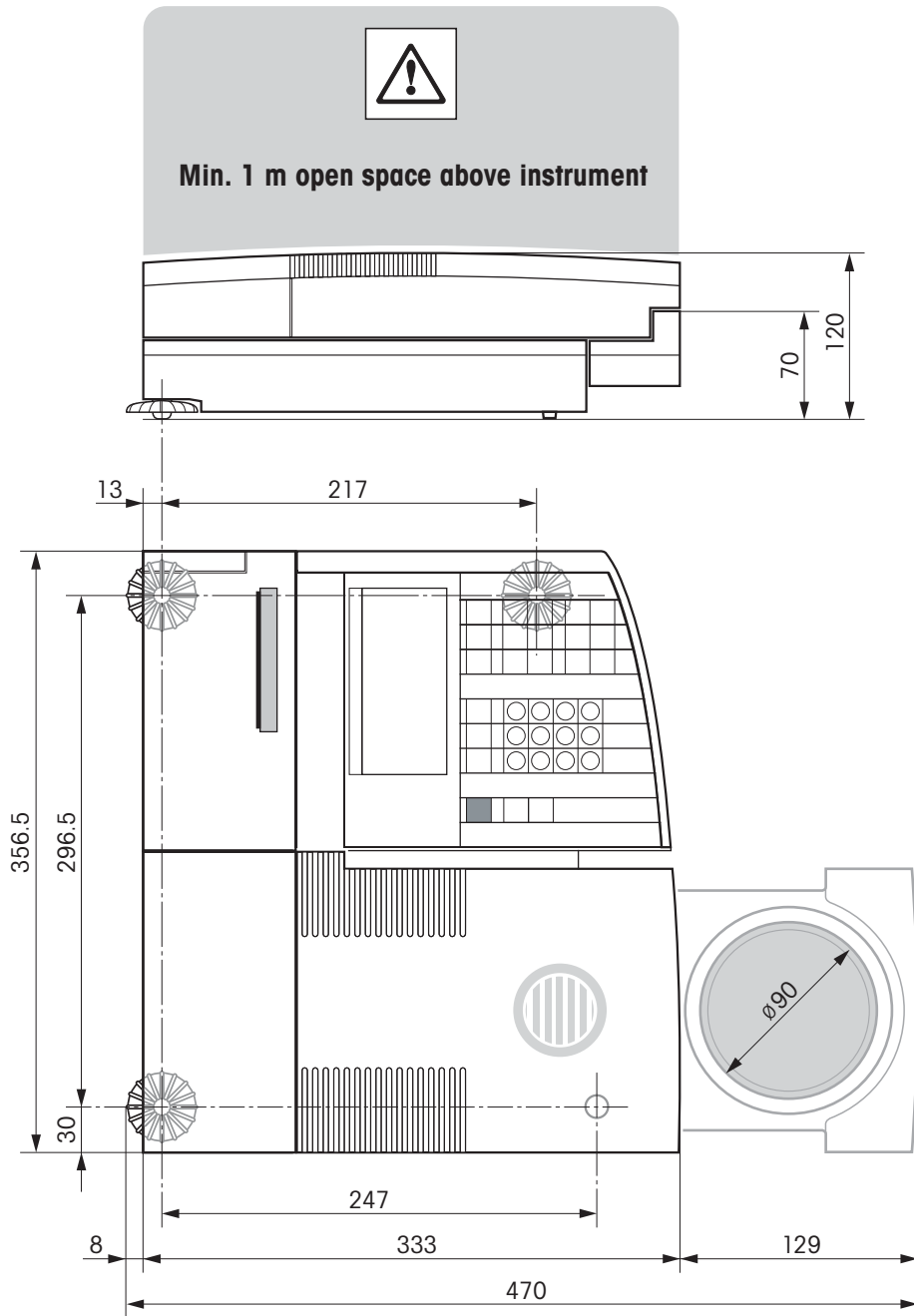

9.8 MT-SICS Interface commands and functions

Many of the instruments and scales used have to be capable of integration in a complex computer or data acquisition system.

To enable you to integrate instruments in your system in a simple manner and utilize their capabilities to the full, most instrument functions are also available as appropriate commands via the data interface.

All new METTLER TOLEDO instruments launched on the market support the standardized command set "METTLER TOLEDO Standard Interface Command Set" (MT-SICS). The commands available depend on the functionality of the instrument.

Basic information on data interchange with the instrument

The instrument receives commands from the system and acknowledges the command with an appropriate response.

Command formats

Commands sent to the instrument comprise one or more characters of the ASCII character set. Here, the following must be noted:

- Enter commands only in uppercase.
- The possible parameters of the command must be separated from one another and from the command name by a space (ASCII 32 dec., in this description represented as $_$).
- The possible input for "text" is a sequence of characters of the 8-bit ASCII character set from 32 dec to 255 dec.
- Each command must be closed by $C_{R/L}$ (ASCII 13 dec., 10 dec.).

The characters $C_{R/L}$, which can be inputted using the Enter or Return key of most entry keypads, are not listed in this description, but it is essential they be included for communication with the instrument.

Example

S – Send stable weight value

Command	S	Send the current stable net weight value.
Response	S$_$S$_$WeightValue$_$Unit	Current stable weight value in unit actually set under unit 1.
	S$_$I	Command not executable (balance is currently executing another command, e.g. taring, or timeout as stability was not reached).
	S$_$+	Balance in overload range.
	S$_$-	Balance in underload range.

Example

Command	S	Send a stable weight value.
Response	S$_$S$_$50.000$_$g	The current, stable weight value is 50.000 g.

The MT-SICS commands listed below is a selected list of available commands. Commands and further information please refer to the Reference Manual "MT-SICS for Halogen Moisture Analyzers HR83/HG63 11780559" downloadable from the Internet under www.mt.com/moisture.

Commands and responses MT-SICS level 0

IO	Inquiry of all implemented MT-SICS commands
I1	Inquiry of MT-SICS level and MT-SICS versions
I2	Inquiry of instrument data
I3	Inquiry of SW version and type definition number
I4	Inquiry of serial number
S	Send stable weight value
SI	Send weight value immediately
SIR	Send weight value immediately and repeat
Z	Zero
ZI	Zero immediately
@	Reset

Commands and responses MT-SICS level 1

D	Display
DW	Weight display (Display show Weight)

Commands and responses MT-SICS level 2

DAT	Date
PWR	Power on/off
P100	Print out text on the strip printer
TIM	Time

Commands and responses MT-SICS level 3

Control commands

HA01	Reset application / escape
HA02	Set factory settings
HA03	Switch keypad on/off
HA04	Open / close automatic sample chamber
HA05	Start / end drying
HA06	Trigger audio signal
HA07	Report instrument status change
HA08	Request printer record

Status inquiries

HA20	Inquiry of instrument status
HA21	Inquiry of automatic sample chamber position
HA22	Inquiry of last balance adjustment
HA221	Inquiry of last balance adjustment test
HA23	Inquiry of last heating module adjustment
HA231	Inquiry of last heating module adjustment test
HA232	Inquiry of heating module adjustment test 1
HA24	Inquiry of temperature
HA25	Inquiry of drying weights
HA26	Inquiry of drying data
HA27	Inquiry of drying result
HA28	Inquiry of drying result with free factor

Instrument settings

HA40	Inquiry / setting of language
HA401	Inquiry / setting of start mode (operating mode)
HA402	Inquiry / setting of key protection (reset protection)
HA403	Inquiry / setting of printer on/off
HA411	Menu parameter: Setting of vibration adapter
HA412	Menu parameter: Setting of acoustic signal
HA413	Menu parameter: Symbols displayed

HA414	Menu parameter: Activate / deactivate recording of company name
HA415	Menu parameter: Definition of company name
HA416	Menu parameter: Definition of department name
HA417	Menu parameter: Select record length
HA418	Menu parameter: Activate / deactivate free print interval
HA419	Menu parameter: Definition of free print interval
HA420	Menu parameter: Activate / deactivate methods option
HA421	Menu parameter: Activate / deactivate statistics and journal function
HA422	Menu parameter: Selective deletion of comment lines
HA423	Menu parameter: Definition of test weight
HA424	Menu parameter: Definition of test weight tolerance
HA60	Select method
HA61	Inquiry / setting of method parameters (part 1)
HA62	Inquiry / setting of method parameters (part 2)
HA621	Definition of "Code 1" comment line
HA622	Definition of "Code 2" comment line
HA623	Definition of "Code 3" comment line
HA624	Definition of "Code 4" comment line

Methods menu

HA631	Activate / deactivate free switch-off criterion
HA632	Activate / deactivate of freely selectable switch-off criterion
HA633	Activate / deactivate free %MC factor
HA634	Definition fo free %MC factor
HA635	Activate / deactivate free g factor
HA636	Definition of free g factor
HA637	Activate / deactivate link method
HA638	Definition of linked method
HA639	Setting of sign for free %MC factor set
HA641	Activate / deactivate high resolution (0.1 mg /1 mg)
HA642	Activate / deactivate standby temperature
HA643	Define standby temperature
HA646	Activate / deactivate drying temperature up to 200 °C without time limitation

Weighing-in aid

HA650	Weighing-in aid no / passive / active
HA651	Weighing-in aid: definition of tolerance range

Method results

HA80	Inquiry of journal
HA81	Inquiry of journal after a certain time
HA82	Clear journal
HA83	Inquiry of statistics
HA84	Delete statistics
HA90	Report keys
HA91	Alphanumeric entry
HA92	Integer entry (positive values only)
HA93	Real entry (positive values only)
HA94	Date entry
HA95	Time entry

9.9 Optional equipment, expendable material and spare parts

Designation	Order No.	Notes
Optional equipment		
Adjustment weight 50 g (Class F1)	00015865	Adjustment of balance
Temperature adjustment set, HA-TC	00214455	Adjustment of heating module
Calibrated temperature adjustment set, HA-TCC (including test certificate at 50 °C, 100 °C and 160 °C)	00214528	Adjustment of heating module
Recalibration from HA-TCC, HA-TCCRe (including test certificate at 50 °C, 100 °C and 160 °C)	00214534	Recalibration with certificate
Interface cable LC-RS25 (RS232/25-pin)	00229050	
Interface cable LC-RS9 (RS232/9-pin)	00229065	
Built-in printer, HA-P43	00214456	
Reusable sample pan (steel, height: 6 mm), HA-DR1	00214462	Set of 3 piece
Reusable sample pan (steel, height: 15 mm)	00013954	1 piece
Transport case, HA-CASE	00214515	
Sample pan handler, HA-PH	00214526	3 piece
Chemically resistant protective cover, HA-COVER	00214533	2 piece
Textile sample pan for bulky samples, HA-CAGE	00214695	1 piece
Barcode Reader (components required)		
Barcode scanner RS232	21900879	
Cable RS 0.3 m, (M-M X)	21900924	
Interface cable LC-RS9 (RS232/9-pin)	00229065	
Power supply 110 V	21900883	
or		
Power supply 230 V	21900882	
Expendable material		
Printer paper for HA-P43	00072456	Set of 5 rolls
Paper roll (self-adhesive) for HA-P43	11600388	Set of 3 rolls
Ribbon (cassette, black) for printer HA-P43	00065975	Set of 2 piece
Aluminum sample pan ø 90 mm, HA-D90	00013865	Set of 80 piece
Reinforced aluminum sample pan ø 90 mm	11113863	Set of 80 piece
Glass fiber filter (for liquids), HA-F1	00214464	Set of 100 piece
Spare parts		
Heating module 110 V HA-HM110	00214737	
Heating module 230 V HA-HM230	00214738	

If you require other spare parts for your Moisture Analyzer, please contact your METTLER TOLEDO dealer.

10 Index

Symbols

%DC display mode 58

%MC display mode 57

A

A...Z 38, 53, 85

Accept entry 17, 26, 52, 69, 71

Accuracy 103

Activate edit mode 54

AddMet 59

Adjusting the balance 73

Adjusting the heating module 75

Adjustment 23

Adjustment of the balance 73

Adjustment of the heating module 75

Adjustment record 74, 77

Adjustment weight 73, 111

Air bubble 12

Alarm clock symbol 83

Application brochure 104

Application error 96

ATRO dry content 34

ATRO moisture content 34

Audio signal 83, 96

AutoMet 6, 22, 48, 49, 50, 56

AutoMet test measurement 47, 48, 49, 50

B

Balance adjustment 69, 73, 88

Balance test 75

Barcode Reader 39, 104, 111

Basic setting 69

Battery 13

Built-in battery 13

Built-in printer 15, 85, 94, 100, 111

Burning 8

C

Check the heating module adjustment 77, 79

Checking the balance adjustment 88

Cleaning 91

Code 38

Comment 38

Comment lines 38, 87

Company 85

Company name 39, 85

Compiling methods 58

Computer 103

Control system 103

Corrosion 8

D

Date 16, 82

Deactivate password 72

Defining the test weight 88

Delete 25, 38, 53, 85

Department name 39

Dialog language 89

Display 99

Display mode 33, 44

Disposal 9

Draft shield element 14, 91

Dry content 33, 34

Drying and measurement 20

Drying curve 48

Drying profile 48, 50

Drying program 26

Drying temperature 22, 23, 27, 28, 44

Drying time 22, 23, 32, 44, 100

E

Equipment 11

Error messages 96, 97, 100

Expendable material 111

Explosion 8

Extended measurement record 41

Extension cable 13

F

Factory settings 80

Fire 8

Free factor (-MC) 57

Free factor (g) 58

Free print interval 35, 86

Free space 14, 18

Free switch-off criterion 31, 32, 104

Freely selectable switch-off criterion 56

Function keys 25

Function symbols 84, 99

Functions 71

G

Gentle drying 26, 28

Glass fiber filter 18, 24, 111

GLP 23

GMP 23

H

Halogen heating module 6

Halogen Moisture Analyzer 6

Heat accumulation 8

Heating module 6, 8, 13, 20, 22, 23, 44, 75, 91, 92, 94, 101, 107, 111

Heating module adjustment 69, 78, 80, 98

Heating module test 78, 79

Heating module test-1 79

High resolution 60

I

Initial status 18

Input errors 96

- Inspection window 76, 79
 - Instrument safety 7
 - Interface 103
 - Interface cable LC-RS25 111
 - Interface cable LC-RS9 111
 - Interface commands 103, 109, 110
 - ISO 14001 7
 - ISO 9001 23
- J**
- Journal 65, 71
 - Journal functions 87
- L**
- Language 16, 89
 - Level 12
 - Level indicator 12
 - Leveling 12
 - Leveling screws 12
 - Line voltage 13, 99
 - LocalCAN universal interface 7, 103
 - Location 12, 97, 100
 - Locking keys 84
- M**
- Manual printout 35
 - Manual switch-off criterion 31
 - Mean value 67
 - Measured value journal 65
 - Measured value statistics 66
 - Measurement 11, 18, 42
 - Measurement parameters 22
 - Measurement record 38, 39, 40, 41, 86
 - Menu 17, 56, 69, 90
 - Menu overview 90
 - Method 52, 56, 63, 64, 71
 - Method memory 81
 - Method menu 55, 70
 - Method menu overview 55
 - Method name 52
 - Method number 52
 - Method parameters 50
 - Method settings 70
 - Methods 26, 51
 - Moisture 6
 - Moisture content 20, 33, 34
 - Moisture determination 24
 - MT-SICS 109
- N**
- Numeric entries 25
 - Numeric keypad 25, 52, 53, 55, 86, 88
- O**
- On/Off 13, 16, 18, 98
 - Open/close auto sample chamber 14, 18, 42, 83
 - Operating mode 83
 - Operating principles 25
 - Optional equipment 111
 - Overheating 8, 101
- P**
- Package 11
 - Paper feed 16, 92
 - Paper roll 16, 111
 - Parameters 22, 54
 - Password 84, 98, 100
 - Password protection 6, 70
 - Personnel qualification 6
 - Poisoning 8
 - Power cable 13, 99
 - Power line fuses 93, 99
 - Power supply 12, 13, 111
 - Print 35, 44, 64, 65, 69, 70, 71, 74, 75, 77, 78, 80, 96
 - Print interval 35, 86, 100
 - Printer 15, 85, 100, 111
 - Printer paper 92, 111
 - Printer test 94, 100
 - Printing out methods 63
 - Protecting your settings 84
 - Protective cover 111
 - Protective glass 8, 92
 - Protective glass of the heating module 94
- Q**
- Quality assurance system 23
- R**
- Ramp 26, 28
 - Rapid drying 26, 27
 - Ready for start 19
 - Ready for taring 18
 - Ready for weighing 19
 - Record 38, 41, 46, 47, 59, 63, 64, 69, 74, 75, 77, 78
 - Reference Manual 103
 - Repeatability 103
 - Reset 17, 21, 45, 64, 65, 67, 69, 70, 71, 72, 96, 98
 - Ribbon 15, 92, 111
 - Ribbon cassette 15
 - Roll of paper 16, 92
- S**
- Safety 7
 - Sample 18
 - Sample chamber 7, 41, 83, 100
 - Sample ID 38
 - Sample pan 19, 24, 73, 111
 - Sample pan handler 19, 111
 - Sample pan holder 14, 91, 99
 - Sample preparation 23
 - Sample weight 103
 - Scroll down 17, 25, 52, 69, 71
 - Scroll up 17, 25, 52, 69, 71
 - Selective clearing 87
 - Self-test 16
 - Servicing 91
 - Set password 70, 71
 - Setting up 12
 - Settings 71

- Signal 20, 44, 83, 96
- Spare parts 111
- Special character 38, 53, 85
- Specimen sample 18, 19
- Stability detector 69, 100
- Standard deviation 67
- Standard drying 26, 27
- Standard equipment 11
- Standard-length measurement record 41
- Standby switch-off time 61
- Standby temperature 60
- Standby time 61
- Start 20, 43, 76, 78, 79, 83, 100
- Stat. 66
- Statistics 66, 71
- Statistics functions 87
- Status display 7, 18, 42
- Step drying 27, 28
- Stop 31, 42, 45, 46
- Switch-off criterion 6, 30, 44, 98, 100
- Symbol 84
- System errors 96
- T**
- Tare (zero) 19, 43
- Target 47, 48, 49, 97
- Target temperature 79
- Target value 47, 48
- Target weight 88
- Target weight (Weighing-in aid) 36
- Technical data 106
- Temperature 98
- Temperature adjustment set 76, 78, 79, 111
- Temperature extension 63
- Temperature limitation 30
- Temperature sensor 91
- TEST 74, 77
- TEST 1 79
- Test measurement 6, 22, 23, 32, 46, 47, 50
- Test record 75, 78, 80
- Testing the heating module 77
- Textile sample pan 111
- Thermogravimetric principle 6, 22, 23
- Time 16, 81
- Time limit 30
- Timed switch-off 32
- Tolerance for balance test 88
- Tolerance range 88
- Transport arrestment 11, 13
- Transport case 111
- Type of record 86
- U**
- Unpacking 11
- User guide 18, 42
- V**
- Vent over 8
- Vibration adapter 82
- W**
- Weighing in 36
- Weighing-in aid 36, 100
- Weight in grams 33
- Weight limits 37
- Weight loss per unit of time 30, 104
- Weight tolerance 37

**To protect your METTLER TOLEDO product's future:
METTLER TOLEDO service assures you of quality, measuring accuracy
and preservation of value of the METTLER TOLEDO products for years
to come.**

Please send for details of our attractive terms of service.

Thank you.



P11780514

Subject to technical changes and to the availability
of the accessories supplied with the instruments.

© Mettler-Toledo AG 2007 11780514B Printed in Switzerland 0710/2.12

Mettler-Toledo AG, Laboratory & Weighing Technologies, CH-8606 Greifensee, Switzerland
Phone +41-44-944 22 11, Fax +41-44-944 30 60, Internet: <http://www.mt.com>